

# larcore<sup>®</sup> A2

Aluminium honeycomb panels for architectural envelopes

TECHNICAL INFORMATION NOTEBOOK



**Alucoil<sup>®</sup>**

Grupo Alibérico



**larcove® A2**  
Aluminium honeycomb panel

---



Toorak Park, Vic. Armadale Australia.  
**larcove® A2 6 mm.** Pure White, Silver, Champagne, 7035 and Anodized Look Dark Grey  
Architect: Denton Corker Marshall.



EI8HT South Esplanade, Glenelg Australia.  
**larcove® A2 6 mm.** Traffic White  
Architect: Chasecrown

## ÍNDEX.

- 1. General considerations. Pag. 4.**
- 2. Where and how rise the honeycomb core panel?. Pag. 5.**
- 3. Products range. Pag. 6.**
- 4. Dimensionals characteristics. Pag. 6.**
  - 4.1. Metal thickness.
  - 4.2. Panel thickness.
  - 4.3. Panel weight.
  - 4.4. Maximum and minimum length.
  - 4.5. Standard width.
- 5. Mechanical dimensional characteristics of the aluminium. Pag. 7.**
  - 5.1. Rigidity EI (kNcm<sup>2</sup>).
  - 5.2. Moment of inertial (mm<sup>4</sup>).
- 6. Mechanical dimensional characteristics of the aluminium. Pag. 7.**
  - 6.1. Modulus of elasticity E (N/mm<sup>2</sup>).
  - 6.2. Elasticity limit R<sub>p0.2</sub> (N/mm<sup>2</sup>).
  - 6.3. Ultimate tensile strength R<sub>m</sub> (N/mm<sup>2</sup>).
  - 6.4. Elongation A (%).
- 7. Possibilities of larcore® A2 for architectural solutions. Pag. 8-11.**
- 8. Certifications and full scale test. Pag. 12-13.**
- 9. Differents types of coating. Pag. 14.**
- 10. Comparative table about types of coating. Pag. 15.**
- 11. Transport and storage. Pag. 16.**
- 12. Identification and recommendations about how install larcore® A2. Pag. 16-17.**
- 13. Lineal thermal expansion of aluminium. Pag. 18.**
- 14. Inspection and maintenance guidelines. Pag. 19-21.**
- 15. Wind loads and pressure. Pag. 22-23.**
- 16. larcore® A2 6 mm panel - Hidetech® LIGHT installation system of the cassettes. Pag. 24-43.**
  - a) larcore® A2 6 mm machining to install with Hidetech® LIGHT.
  - b) Speed and advance in the cutting and routing operations of the panel in the Alucoil's machines.
  - c) Hidetech® LIGHT installations system developmnet by Alucoil®.
- 17. larcore® A2 14 mm panel - Hidetech® PRO installation system of panels. Pag. 44-61.**
  - a) larcore® A2 14 mm machining to install with Hidetech® PRO.
  - b) Speed and advance conditions to edged panel in Alucoil's machines.
  - c) Hidetech® PRO installations system developmnet by Alucoil®.



## 1. General considerations.

- When the **Iarcoring® A2** is used for exterior façades it must be installed with a system approved by **Alucoil®** (**Hidetech® PRO** or **Hidetech® LIGHT** systems) or with any other solution that do guarantee the panel watertightness under the customer's responsibility.
- **Iarcoring® A2** panels must be installed on buildings following always the regulations, technical guidelines and building codes regarding classification and protection against fire of each country where they are to be installed. **Alucoil®** has a wide range of products to meet the requirements of each country.
- It is the responsibility of the customer to prove that they are complying with the end use of the product and with the building regulations or building technical approvals applicable to the place of installation.
- Pallets are to be kept dry during transportation.
- Products must be stored in a dry and cool place and protected from sun, rain and snow.
- The maximum storage period is 8 months. It is recommended that the original pallets are stacked one on top of the other up to a maximum of 6. Wooden blocks should always be matched when stacking.
- For the correct transformation of **Iarcoring® A2** panels, follow the recommendations described in this document, available on **www.alucoil.com**.
- All processing of **Iarcoring® A2** composite sheets must be done at a metal temperature of over 10°C and with the protective plastic film on to prevent damages to the coated surface. The protective plastic film must not be removed until all works on the site have been completed. Do not remove the protective foil using cutters or sharp tools.
- Attend the particularities of each finish, especially Alnatural, Embossed – specific fabrication instructions - and Real Anodized range. If they have not been provided to you by **Alucoil®**, please request them.
- Milling/routing must be done on the back side of the **Iarcoring® A2** panel, i.e., the opposite side of the protective plastic film.
- Install panels ALWAYS in the same direction following the arrows on the protective plastic foil.
- To ensure colour consistency, the total quantity requirement for one project should be ordered at one time.
- Remove the protective foil as soon as possible after installation but at temperatures above 10°C.
- To ensure proper performance of the **Iarcoring® A2** panels, follow the recommendations described in this document, available on **www.alucoil.com**.



## 2. Where and how the honeycomb panel arises.

Throughout history, men have studied the complex development of bees to build their combs, in ancient Rome it was used in the construction of hidden chambers within the Pantheon, in the Asian continent 2000 years ago, mainly in China, artificial paper honeycombs were used in order to be decorative, more recently in the year 1901 artificial paper panels were produced in Germany in the same way for decorative purposes. This year was when the 3 ways in which artificial structures are produced were consolidated, these are: by molding, expansion and corrugation.

The first uses in engineering date back to 1915 by Hugo Junkers, who first patented honeycomb cores within the aerospace industry. For his process he thought to introduce the honeycomb structures instead of the simple sheet structures that were used as cover, his development led him to describe how it is possible to load the sheets with compression if they are in positions supported in small intervals by means of honeycomb-like hollows.

In 1934 Edward G. Budd stated that it was possible to create a combination of a honeycomb structure using steel with corrugated sheet metal. In 1938 Aero Research Limited, a British company specialized in the development of adhesives, achieved an adhesive that allowed the proper formation of fillets in the intervals of the honeycomb. Thanks to this adhesive, the use in North American ships with stainless steel panels became popular.

### Manufacturing

The manufacture of honeycomb structures consists of three techniques: by means of expansion, molding and corrugation. Thanks to developments in the industry, current manufacturing allows compression through the expansion and corrugation process in materials such as aluminum. These processes allow continuous and in-line production with the sandwich panel. For the process that involves metals such as aluminum, the expansion process with different configurations is used, the traditional configuration of a hexagonal core and special configurations that allow to take full advantage of the benefits of honeycomb structures.

### Properties

The properties obtained by the design of the honeycomb structure are achieved thanks to the rigidity and the weight: on the one hand, the weight is considerably light compared to the great rigidity it offers, when the structure is compacted as if it was a sandwich. The resulting features acquire the property of reacting in different orientations thanks to this based on the L and W directions. They also gain the property of being resistant to compression, this is thanks to the hexagonal configuration, the walls of the panels resist a lot compared to others with their same weight that they are not configured in a hexagonal shape. On the other hand, the mechanical properties are obtained in the same way by cell formation, although their resistance varies according to the direction in which a load is applied, the tension is high and the density is low.

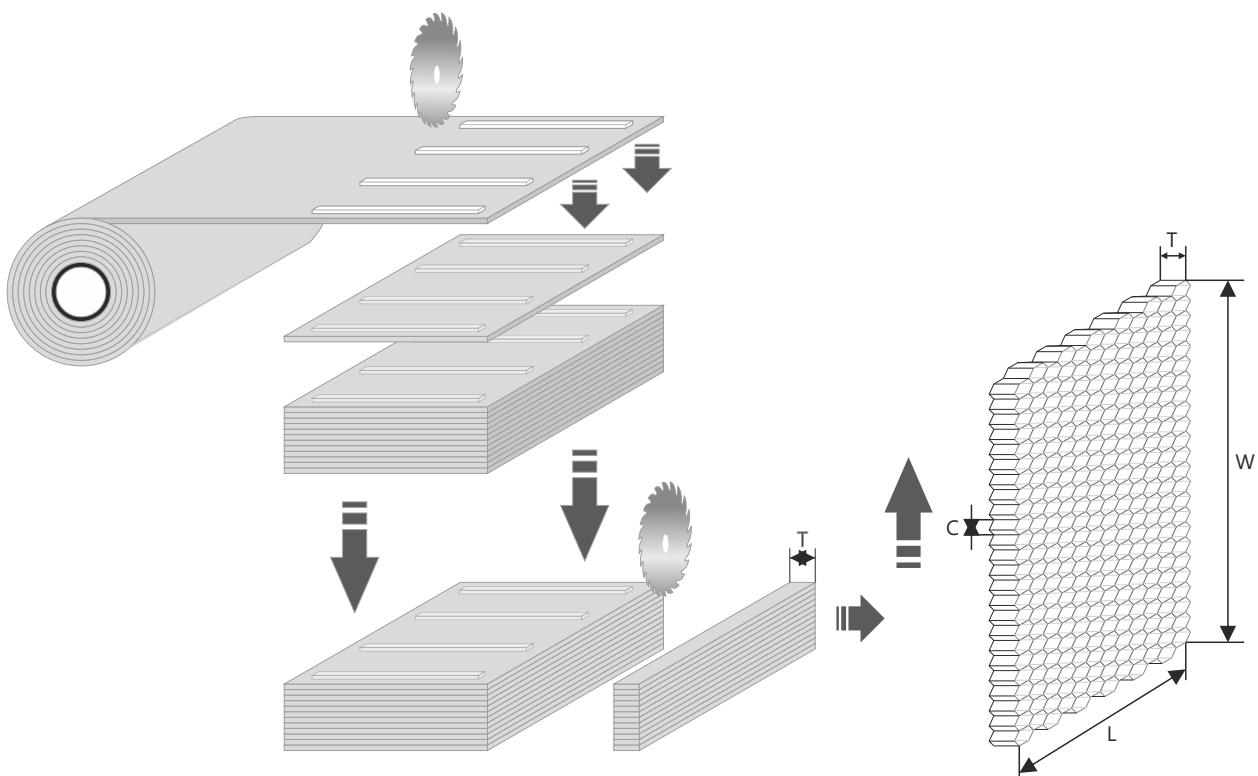



### 3. Products range.

#### Iarcoring® A2.

Metallic panels formed by 2 aluminum sheets joined by an aluminum honeycomb core, designed for architectural facades. Iarcoring® A2 panels for architecture have total thicknesses from 6 mm to 20 mm.

#### Iarcoring® A2 METALS.

Iarcoring® A2 range of panels with ZINC sheets and aluminum honeycomb core. This range is developed for panels with a total thickness of 15 mm.

Alucoil® has developed specific installation systems for these panels under the Hidetech® brand.

# Iarcoring® A2

## Aluminium honeycomb core panel.



## Iarcoring® A2 panel with EPD® Environmental product declaration

We have a range of high-quality finishes, with PVDF COASTAL PRIMER liquid paints (Kynar and Hylar as main brands) and FEVE under the fluorlac® brand, through which we achieve solid, metallic colors and the SPECIAL LLUSIONS range (holos, alunatural, anodized look and textured & design).

### 4. Dimensional characteristics of Iarcoring® A2

4.1. Metal thickness "e<sub>1</sub> / e<sub>2</sub>" (mm). The thickness of the outer sheet metal (e<sub>1</sub>) and the thickness of the inner sheet metal (e<sub>2</sub>)

4.2. Panel thickness. The thickness of the composite panel is measured in millimeters (mm) and it is the sum of the thickness of the outer metal sheet (e<sub>1</sub>) + core thickness (FR or A2) + the thickness of the inner sheet metal (e<sub>2</sub>).

4.3. Panel weight (Kg/m<sup>2</sup>). The weight changes depending on the panel thickness, type of metal and metal thickness, and the type of core.

4.4. Minimum and maximum length "L" (mm). Alucoil® can fabricate a minimum length of 2000 mm due to the characteristics of its production line. Shorter lengths may be obtained after cutting panels. The maximum length produced is 8000 mm because of CNC machine dimensions of Alucoil®.

4.5. Standard width "H" (mm). Aluminium standard widths are 1000 / 1250 / 1500 mm. It is also possible to produce on request any width between 900mm and 2000mm.

## 5. Mechanical properties of larcore® A2.

5.1. Rigidity "EI" (KNcm<sup>2</sup>): rigidity is calculated multiplying the moment of inertia by elastic modulus, under given load and support configurations. The higher the rigidity, the lower deflection obtained.

5.2. Moment of inertia "I" (mm<sup>4</sup>): section property that quantifies its amount of mass (area) in relation to its gravity center. Stress and deflection obtained under a certain load applied to a panel are directly influenced by its moment of inertia (the greater the inertia, the less stress and deflection under the same load).

### FOUR POINTS BENDING TEST ACCORDING TO DIN 53 293

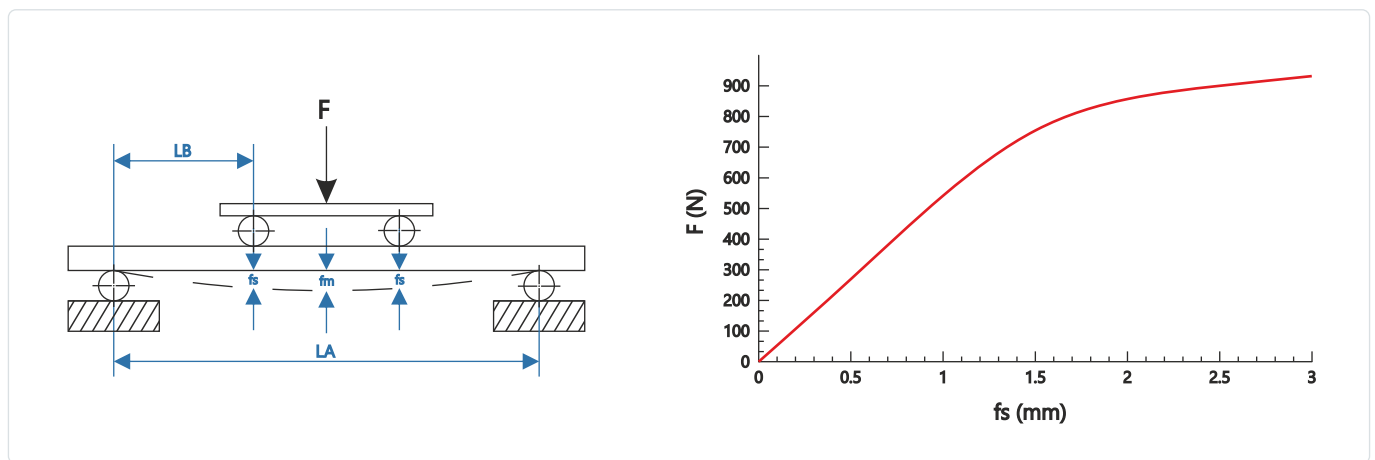

## 6. Mechanical properties of aluminium.

6.1. Modulus of elasticity "E" (N/mm<sup>2</sup>): also known as Young Modulus, it is a typical constant of elastic materials that relates the force applied to the deflection or displacement obtained. The higher the modulus of elasticity the lower deflection for a given load.

6.2. Elasticity limit " $R_{p0.2}$ " (N/mm<sup>2</sup>): maximum stress an elastic material can stand so it can recover from obtained deflection up to 99.8% once the applied force is removed. The higher the limit, the more difficult to cause permanent deformation of the panel.

6.3. Ultimate tensile strength " $R_m$ " (N/mm<sup>2</sup>): material breakage stress. Once the yield strength is exceeded, the material continues deforming without breaking, but undergoes plastic deformation (non-recoverable deformation). The material breaks when it reaches its ultimate tensile strength.

6.4. Elongation "A" (%): length increase of an element (expressed in percentage) since it exceeds the elasticity limit until the breakage appears.

### Main properties of the aluminium:

- Low density.
- Good formability.
- Resistance to corrosion.
- Heat conduction.
- Impact resistance.
- Electricity conduction.
- High resistance.
- Recyclability.
- Surface treatments such as painting or anodizing.





**7. Possibilities of Iarcoring® A2 panels for architecture.**

# Iarcoring® A2 6 mm

6 mm aluminium honeycomb panels and installation system of cassettes development by **Alucoil®**.

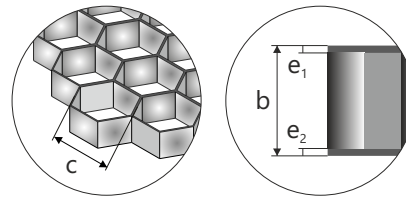

- Protective film
- 0,7 mm coated aluminium** 5005 EN 573-3
- Bonding layer
- Aluminium honeycomb core**
- Bonding layer
- 0,5 mm aluminium** 5005 EN 573-3

**Features of the panel**

<b>Total thickness "b"</b> Width tolerance ≤ 1600 mm: ±0,2 mm Width tolerance > 1600 mm: -0,1 / +0,5 mm	<b>6 mm</b>
<b>External skin thickness "e<sub>1</sub>"</b>	<b>0,7 mm</b>
<b>Internal skin thickness "e<sub>2</sub>"</b>	<b>0,5 mm</b>
<b>Weight</b>	4,19 kg/m <sup>2</sup>
<b>Standard width</b> Tolerance -0 / +2 mm	1250 <sup>(1)</sup> mm 1500 <sup>(1)</sup> mm 1575 mm 2000 <sup>(2)</sup> mm
<small><sup>(1)</sup>Standard width <sup>(2)</sup>In the 2000 mm width the external and internal aluminium sheets are of 0,7 mm thickness.</small>	
<b>Length</b> Tolerance -1 / +6 mm a) min. b) max.	a) 2000 mm b) 14000 mm

**Mechanical features of the panel**

The purpose of the mechanical values is to be able to compare different product configurations. Specific calculations for each project must be requested to the **Alucoil®** technical department.

<b>Rigidity (EI)</b> DIN 53293 a) Transversal axis b) Longitudinal axis	a) 2825 kNcm <sup>2</sup> /m b) 2386 kNcm <sup>2</sup> /m
<b>Acoustic insulation (R<sub>(A)</sub>)</b> ISO 10140-2	19,54 dBA
<b>Thermal resistance (R)</b>	0,0067 m <sup>2</sup> K/W

**Coated aluminium skin features**

<b>Aluminium alloy</b> (ext. int.)	5005 <sup>(1)</sup> EN 573-3
<b>Yield strength (R<sub>p0,2</sub>)</b>	>80 N/mm <sup>2</sup>
<b>Ultimate tensile strength (R<sub>m</sub>)</b>	125 < R <sub>m</sub> < 185 N/mm <sup>2</sup>
<b>Elongation (A)</b>	>3%

<sup>(1)</sup>Other alloy availables.

**Core features**

<b>Aluminium alloy</b>	3005 <sup>(1)</sup> EN 573-3
<b>Cell size</b>	1/4" ≈ 6,35 mm
<b>Foil thickness</b>	50µ
<b>Compressive strength</b>	2,20 MPa DIN 53291
<b>Density (ρ)</b>	56 kg/m <sup>3</sup>



# larcore® A2 14 mm

14 mm aluminium honeycomb panels and installation system of panels with double edged development by **Alucoil®**.

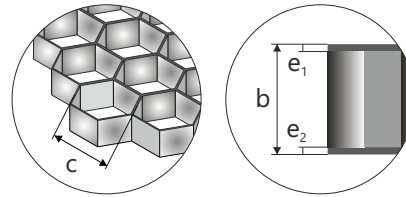
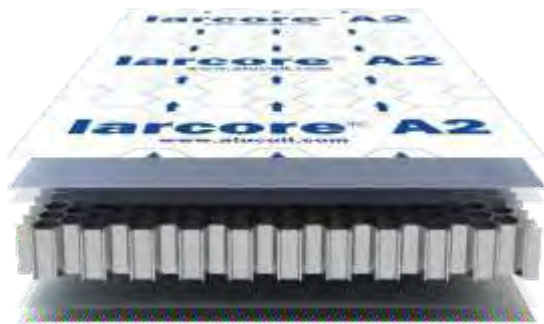

- Protective film
- 1,0 mm coated aluminium** 5005 EN 573-3
- Bonding layer
- Aluminium honeycomb core**
- Bonding layer
- 1,0 mm aluminium** 5754 EN 573-3

## Panel features

<b>Total thickness "b"</b> Tolerance ±0,2 mm	<b>14 mm</b>
<b>External skin thickness "e<sub>1</sub>"</b>	<b>1,0 mm</b>
<b>Internal skin thickness "e<sub>2</sub>"</b>	<b>1,0 mm</b>
<b>Weight</b>	6,75 kg/m <sup>2</sup>
<b>Standard width</b> Tolerance -0 / +2 mm	1000 mm 1250 mm 1500 mm 2000 mm
<b>Length</b> Tolerance -1 / +6 mm a) min. b) max.	a) 2000 mm b) 14000 mm

## Aluminium skin features

<b>Aluminium alloy</b> a) External skin b) Internal skin	a) 5005 <sup>(*)</sup> EN 573-3 b) 5754 <sup>(*)</sup> EN 573-3
<b>Yield strength (R<sub>p0,2</sub>)</b> a) External skin b) Internal skin	a) >80 N/mm <sup>2</sup> b) >220 N/mm <sup>2</sup>
<b>Ultimate tensile strength (R<sub>m</sub>)</b> a) External skin b) Internal skin	a) 125 < R <sub>m</sub> < 185 N/mm <sup>2</sup> b) >280 N/mm <sup>2</sup>
<b>Elongation (A)</b> a) External and internal skin	>3%

## Mechanical features of the panel

The purpose of the mechanical values is to be able to compare different product configurations. Specific calculations for each project must be requested to the **Alucoil®** technical department.

<b>Rigidity (EI)</b> (kNcm <sup>2</sup> /m) DIN 53293	<b>TOP VALUE<sup>(*)</sup></b>
<sup>(*)</sup> Extra rigid premium panel for use with <b>Hidotech® PRO</b> system. All necessary calculations are provided by our technical department.	
<b>Acoustic insulation (R<sub>a</sub>)</b> ISO 10140-2	21,56 dBA
<b>Thermal resistance (R)</b>	0,0086 m <sup>2</sup> K/W

## Core features

<b>Aluminium alloy</b>	3005 <sup>(*)</sup> EN 573-3
<b>Cell size</b>	1/4" ≈ 6,35 mm
<b>Foil thickness</b>	50μ
<b>Compressive strength</b>	2,20 MPa DIN 53291
<b>Density (ρ)</b>	56 kg/m <sup>3</sup>

<sup>(\*)</sup>Other alloy availables.



# Iarc core® A2 range of panels with 0,7 mm aluminium skins

8 mm - 10 mm - 14 mm - 20 mm<sup>(\*)</sup> panel thickness

<sup>(\*)</sup>20 mm panel with 1 mm aluminium skins

Panels developed for systems present in the market such as glued, riveted or screwed.

## Panel features

<b>Total thickness</b> Tolerance ±0,2 mm	<b>8 mm</b>	<b>10 mm</b>	<b>14 mm</b>	<b>20 mm</b>
<b>External skin thickness</b>	<b>0,7 mm</b>			<b>1,0 mm</b>
<b>Internal skin thickness</b>	<b>0,7 mm</b>			<b>1,0 mm</b>
<b>Weight</b>	4,83 kg/m <sup>2</sup>	4,94 kg/m <sup>2</sup>	5,19 kg/m <sup>2</sup>	7,05 kg/m <sup>2</sup>
<b>Standard widths</b> Tolerance -0 / +2 mm	1250 <sup>(1)</sup> mm / 1500 <sup>(1)</sup> mm / 1575 mm / 2000 mm			
<b>Lengths</b> Tolerance -1 / +6 mm	From 2000 mm to 14000 mm			

<sup>(1)</sup> Anchos estándar.

En el ancho 2000 mm las pieles de aluminio ext. e int. son de 0,7 mm

## Mechanical features of the panel

The purpose of the mechanical values is to be able to compare different product configurations. Specific calculations for each project must be requested to the **Alucoil®** technical department.

	Transversal/Longitudinal	Transversal/Longitudinal	Transversal/Longitudinal	Transversal/Longitudinal
<b>Rigidity (EI)</b> kNcm <sup>2</sup> /m DIN 53293	9421 / 7217	24458 / 22519	49915 / 45958	143868 / 121726

## Coated aluminium skin features

<b>Aluminium alloy</b>	5005 <sup>(1)</sup> EN 573-3
<b>Yield strength (R<sub>p0,2</sub>)</b>	>80 N/mm <sup>2</sup>
<b>Ultimate tensile strength (R<sub>m</sub>)</b>	125 < R <sub>m</sub> < 185 N/mm <sup>2</sup>
<b>Elongation (A)</b>	>3%

<sup>(1)</sup>Other alloy availables.

## Core features

<b>Aluminium alloy</b>	3005 <sup>(1)</sup> EN 573-3
<b>Cell size</b>	1/4" ≈ 6,35 mm
<b>Foil thickness</b>	50µ
<b>Compressive strength</b>	2,20 MPa DIN 53291
<b>Density (ρ)</b>	56 kg/m <sup>3</sup>

For more information, request a product technical sheet or visit [www.alucoil.com](http://www.alucoil.com)

# larcore® A2 Metals Zinc 15 mm

Aluminium honeycomb core panel with zinc sheets manufactured in 15 mm total thickness and with 7 different colour finishes: slate, red, blue, ébano, brown, green and gold

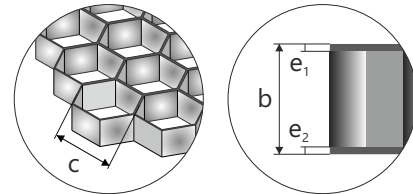

Protective film  
**1,0 mm coated zinc Z1** (>99,995)% EN 988, Z1 EN 1179  
 Bonding layer  
**Aluminium honeycomb core**  
 Bonding layer  
**1,0 mm coated zinc Z1** (>99,995)% EN 988, Z1 EN 1179

## Panel features

<b>Total thickness "b"</b> Tolerances $\pm 0,2$ mm	<b>15 mm</b>
<b>External skin thickness "e<sub>1</sub>"</b>	<b>0,5 mm</b>
<b>Internal skin thickness "e<sub>2</sub>"</b>	<b>0,5 mm</b>
<b>Weight</b>	8,66 kg/m <sup>2</sup>
<b>Standard widths</b> Tolerancias -0 / +2 mm	1000 mm
<b>Length</b> Tolerances -1 / +6 mm a) Mín. b) Máx.	a) 2000 mm b) 8000 mm

## Mechanical features of the panel

The purpose of the mechanical values is to be able to compare different product configurations. Specific calculations for each project must be requested to the **Alucoil®** technical department.

<b>Rigidity (EI)</b> DIN 53293 a) Transversal axis b) Longitudinal axis	a) 86221 kNcm <sup>2</sup> /m b) 57653 kNcm <sup>2</sup> /m
--	--

## Coated zinc skin features

<b>Zinc alloy</b> (ext. int.)	Z1 (>99,995%) EN 988, Z1 EN 1179
<b>Yield strength (R<sub>p0,2</sub>)</b>	>110 N/mm <sup>2</sup>
<b>Ultimate tensile strength (R<sub>m</sub>)</b>	>150 N/mm <sup>2</sup>
<b>Elongation (A)</b>	>35%

For more information, request a product technical sheet or visit [www.alucoil.com](http://www.alucoil.com)



## 8. Certificates - Full-scale fire test & Classifications.

### ENVIRONMENTAL CERTIFICATE

#### International →

Environmental label.

EPD® Environmental product declaration.

-Iarc core® A2 6 mm 0,7/0,5.

-Iarc core® A2 14 mm 0,7/0,7.

-Iarc core® A2 14 mm 1,0/1,0.



### PRODUCT CERTIFICATES WITH INSTALLATION SYSTEM

#### Australia →

CODEMARK.

- Iarc core® A2 6 mm (0,7/0,5) "CM40198".



#### USA →

INTERTEK.

- Iarc core® A2 14 mm (0,7/0,7) and Iarc core® A2 14 mm (1,0/1,0) "SDReport 46046".



#### Ukraine →

UA-TR Building reglament Ukraine.

- Iarc core® A2 8 mm (0,7/0,7) "UA-TR.042.17.18".

### FULL-SCALE FIRE TEST & CLASSIFICATIONS

#### European Union →

Fire performance of external cladding systems. Test method for non-loadbearing external cladding systems fixed to and supported by a structural steel frame.

BS 8414-2/BR 135 - PASSED.

- Iarc core® A2 6 mm with Hidetech® LIGHT system has passed the BR 135 criteria tested according to BS 8414-2.

Fire classification of construction products and building elements.

- Iarc core® A2 range, from 8 mm till 20 mm thickness, Hidetech® PRO system, A2-s1, d0 according to EN 13501-1.

- Iarc core® A2 6 mm Hidetech® LIGHT system, A2-s1, d0 according to EN 13501-1.

#### USA →

Full-scale fire test. Standard Fire Test Method for Evaluation of Fire Propagation Characteristics of Exterior Wall Assemblies Containing Combustible Components.

NFPA 285 - PASSED.

- Iarc core® A2 14 mm with Hidetech® PRO system. PASSED according to NFPA 285.

### Canada →

Standard Method of Fire Test of Exterior Wall Assemblies.

- **larcore® A2 14 mm PASSED according to CANULC S134.**

(larcore A2 14 mm 0.7/0.7) is ULC-S135 compliant to be used in noncombustible construction as defined by the National Building Code of Canada.

## FIRE TEST & CLASSIFICATIONS

### Australia - New Zealand →

Methods for fire tests on building materials, components and structures, Part 1: Combustibility test for materials.

- **larcore® A2 6 mm NOT COMBUSTIBLE according to AS 1530.1.**

Methods for fire tests on building materials, components and structures Simultaneous determination of ignitability, flame propagation, heat release and smoke release.

- **larcore® A2 6 mm according to ASNZS 1530.3.**

### USA →

Standard Test Method for Surface Burning Characteristics of Building Materials.

- **larcore® A2 25 mm according to ASTM E84-15b.**

Standard Test Method for Determining Ignition Temperature of Plastics.

- **larcore® A2 14 mm according to ASTM D1929.**

### Canada →

Standard test method for the determination of combustibility parameters of building materials using an oxygen consumption calorimeter (CONE CALORIMETER).

- **larcore® A2 29 mm NOT COMBUSTIBLE according to ULC S135-04.**

Standard Test Method for Surface Burning Characteristics of Building Materials.

- **larcore® A2 14 mm according to ASTM E84.**

Standard test method for the determination of combustibility parameters of building materials using an oxygen consumption calorimeter (CONE CALORIMETER).

- **larcore® A2 14 mm according to CANULC S135.**



## 9. Different types of coating.

**PVDF (Polyvinylidene Fluoride).** Coating based on PVDF resins (Kynar and Hylar as main brands) with extraordinary performance.

Nominal paint thickness:

a) **PVDF 2L Coastal:** 31 µ approx.

- *Gloss levels from 20 to 40 g.u.*
- *Excellent colour stability, almost no chalking and very good chemical resistance.*
- *Great protection against weathering, UV radiation and atmospheric contaminants.*
- *Outstanding flexibility for profiling, bending and roll forming.*
- *Recommended for demanding environments like industrial and coastal areas, airports, etc.*

**DG5 (High Durable Polyester).** Coating based on HDP resins.

Nominal paint thickness:

a) **DG5 2L Coastal:** 35 µ approx, (depending on the colour)

b) **DG5 3L Coastal:** 55 µ approx, (depending on the colour)

c) **DG5:** 25 µ approx.

- *Gloss levels from 10 to 90 g.u.*
- *Outstanding protection against weathering, UV radiation and atmospheric contaminants.*
- *Excellent hardness and flexibility for profiling, bending and roll forming.*

**PUR/PA (Polyurethane/Polymainde).** Coating based on polyurethane resins.

- *Very flexible and good formability.*
- *Good chemical resistance.*
- *Outstanding scratch resistance and high abrasion resistance.*
- *Good substrate adhesion: also used in primer systems.*

## **NEW fluorlac®** Coating for **Iarc core® A2** panels

FEVE LUMIFLON™ 2 LAYERS. LUMIFLON™ fluoropolymer resins based coating with a nominal thickness of 30µ, (depending on the colour).

### COLOURS:

- *RAL & NCS colour charts with matt, satin and high gloss finishes.*
- *Matched colours.*

### QUANTITIES:

- **Orders from 75 sqm.**

### SERVICES:

- *Very short delivery times, **2-3 weeks.***
- *One face coated with a protective film of 100µ thick.*

### Other characteristics:

- *Excellent weatherability and chemical resistance.*
- *High abrasion resistance.*

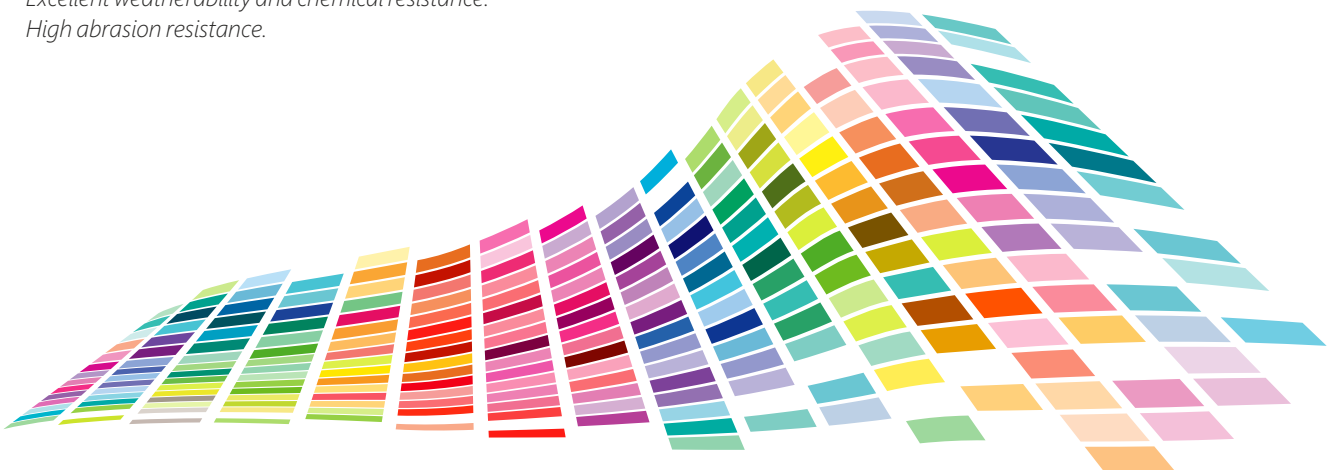

10. Comparative table about types of coating.

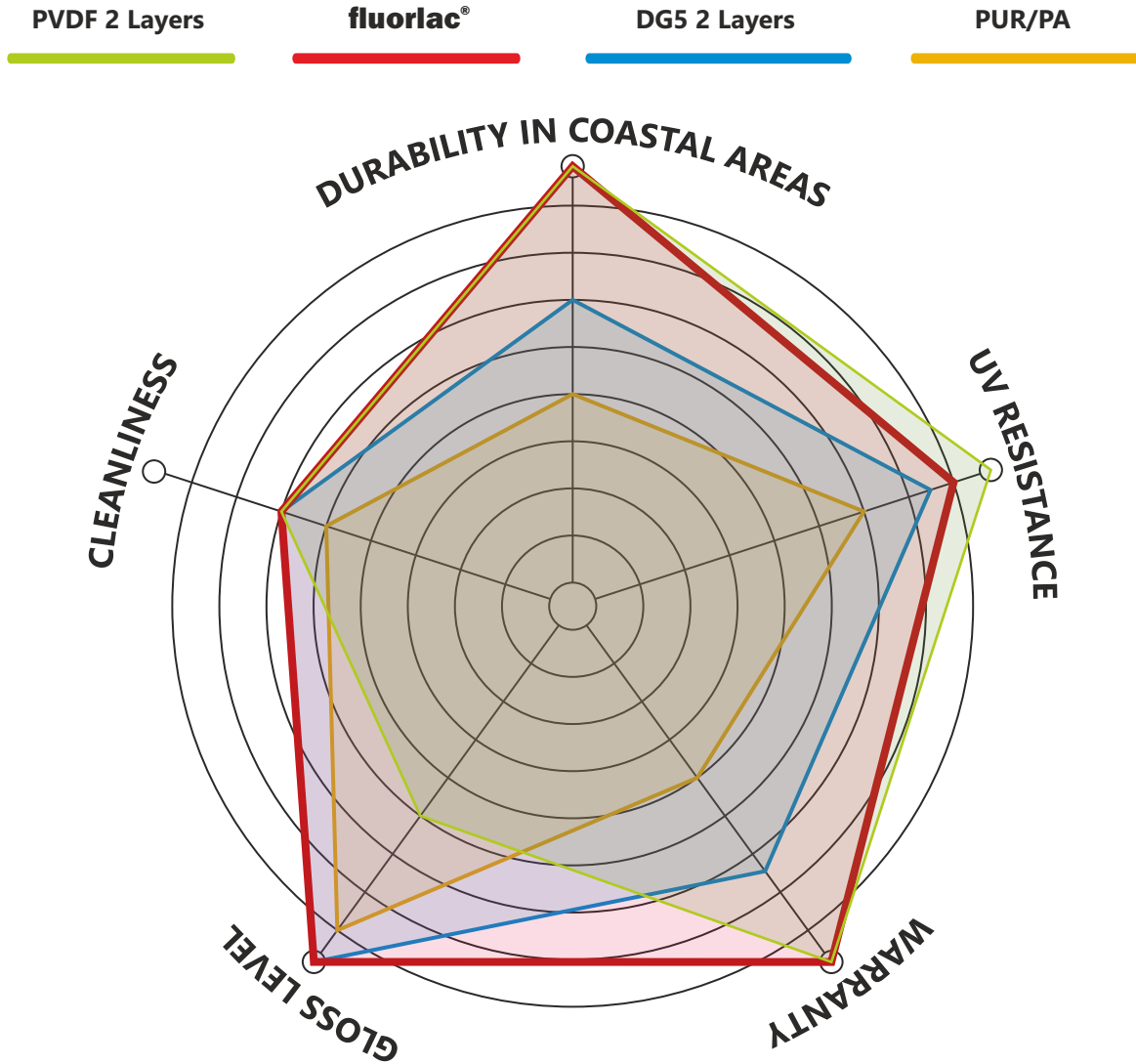

**PVDF**

PVDF 2L Coastal: 31µ  
 Polyvinylidene Fluoride

Liquid paint quality.  
 Wide range of solid and metallic colours.  
 Gloss level limitations (20G - 40G).

**fluorlac®**

FEVE 2L: 30µ  
 Fluoropolymer

Available in small quantities in any RAL & NCS colours.  
 Liquid paint quality.  
 Matt, satin and high gloss finishes.

**DG5 (HDP)**

DG5 2L Coastal: 35µ  
 High Durable Polyester

Maximum versatility of finishes: Holo, Design & Textured (wood-concrete-stones)  
 Super matt 2G - 10G  
 High gloss level 90G

**PUR/PA**

ALUNATURAL 16µ  
 Polyurethane / Polyimander

Transparent special coating for Alunatural finishes.



## 11. Transport and storage.

**Iarc core® A2** is a honeycomb panel with lacquered, foil-laminated or mill-finish surfaces. These surfaces may be protected by a special protective film during transport, storage and machining. The following points must be taken into consideration when storing and handling panels:

Pallets must be handled carefully during transport and unloading. Upon delivery pallets must be examined for any damage. Any detected imperfection must be reported immediately and confirmed by the forwarding agent. Store pallets so that they are protected against wetness penetrating due to rain and spray water and avoid the formation of condensation.

### ATTENTION:



- Caution: do not transport open pallets.
- Stock pallets stacked one above the other with a maximum of 6 pallets of the same format. Heavy pallets must be placed at the bottom. Do not store **Iarc core® A2** panels standing. Individual panels must be lifted off pallet by two people holding all four corners and not drawn over each other. Carry panels vertically. Wear gloves to avoid making any marks on them. To avoid marks, do not place anything between the panels when stacking them.
- When loading and unloading, unpacked plates are to be lifted to avoid possible scratches or other damage. It should be avoided in any case, to move decor sides against each other or to pull one over the other. When transporting stacks of plates with transport vehicles, appropriate pallets are to be used.
- Panels must be stored horizontally.
- Basically, each of the decorative sides of two panels should be stored against each other: the last lying on top of the stack panel should be placed with the decorative side facing the bottom of the stack.
- It is recommended to store the panels in a closed, dry area at temperatures between 10 and 30°C and a humidity of 40-65 %.

## 12. Recommendations for the installation of the composite panel.

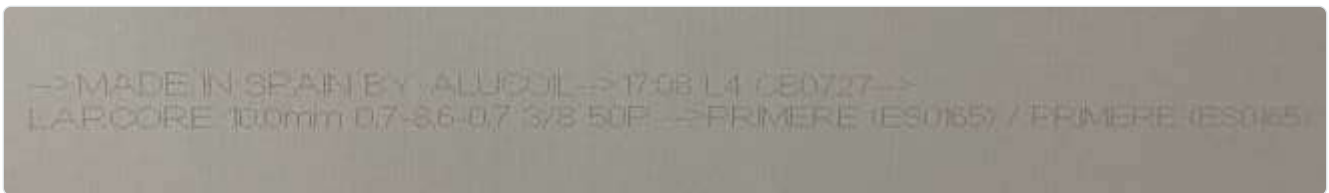
- **Iarc core® A2** panels are marked on the back face during manufacturing process with an alphanumeric code. This is for the tracking of panels in case of any issue.
- Manufacturing batches are correctly labeled with their tracking.
- All panels for the same project should be ordered in one order as there are possible colour differences between different batches.



Digital printing inside the panel

 		Delivery address Pol. Ind. Bayas C/ Ircio Parc. R72/77 Miranda de Ebro España		 <b>SSCC (00) 0000000000000000</b> <b>FR-PG-05C-07; Ed. 1 (15/01/09)</b>		
Description	Colour	Class	Measurements	Order number	Units	Quantity
LC100_0707_3/850P_1C - LARCORE 10.0mm 0.7	PRIMER E (ES065)	SD01	2000x8750	PV0000000	13	67,5 M2
<b>Cust.: Alucoil, S.A.U.</b>		<b>PV: PC-0000/19</b>				
Approximate net weight ...: 425 kg			Approximate gross weight ...: 536 kg			

Manufacturing label



- All **larcore® A2** panels are protected by a protective film which has printed recommendations for removal. This protective film has a series of arrows in its design.
- The panels manufactured by **Alucoil®** must be installed with the arrows of the film in the same direction.

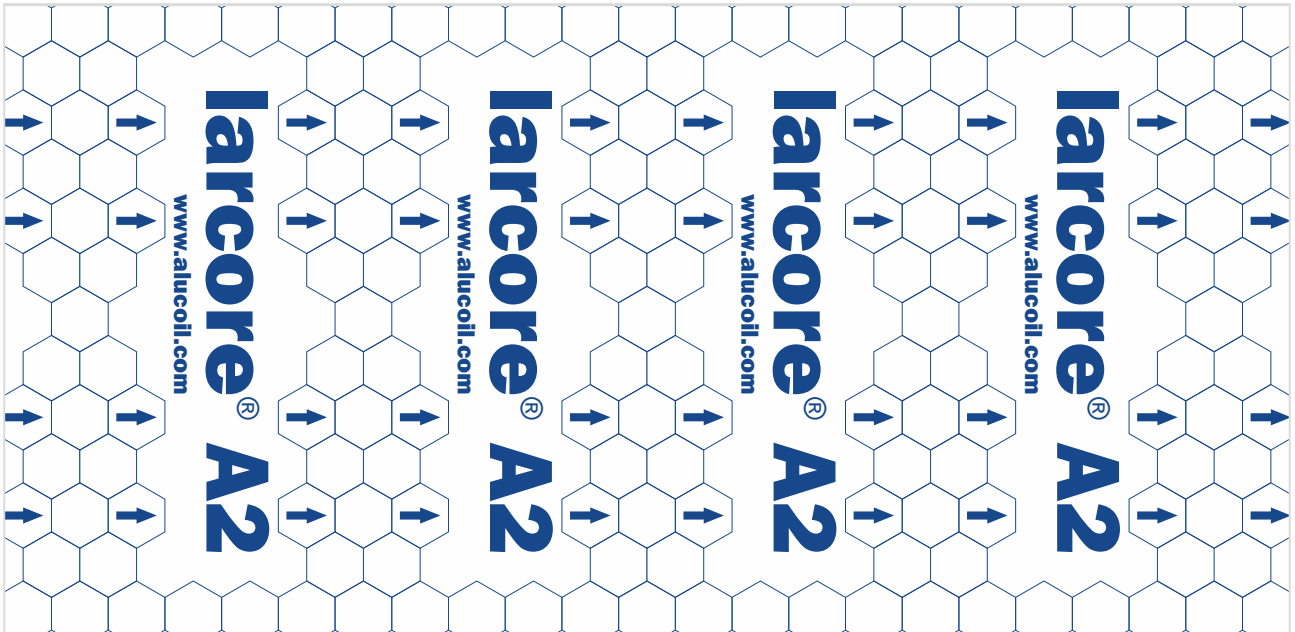

**larcore® A2** protective film

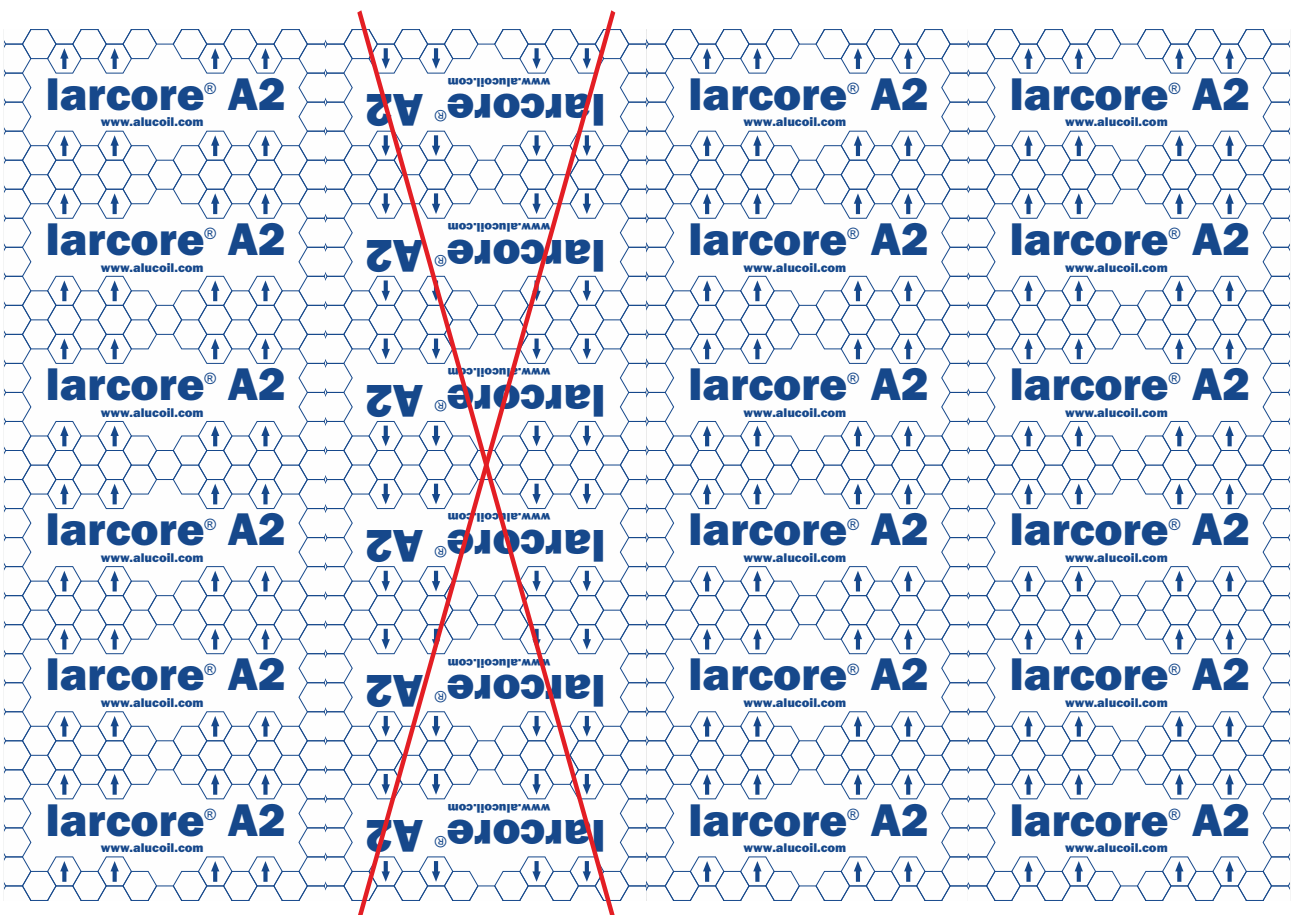

Guidance data, depending on the machine and type of tool used



### 13. Lineal thermal expansion of Aluminium.

Due to thermal influences, the magnitude of contraction or expansion has to be calculated to the size that the joint expansion areas require. This is defined by:  $\Delta L = \alpha \times \Delta T \times L$

Where "α" is the coefficient of expansion of the composite panel and the aluminium:  $2,4 \times 10^{-5} \text{C}^{-1}$ , being " $\Delta T$ " temperature variation and "L" length or height of the cassette/panel.

#### Very important:

- According to the lineal thermal expansion of the panel we must calculate the dimension of the joints between panels.
- Consider expansions in H and V.
- Consider a possible variation of temperature of 100°C.
- Use of retention and support brackets for dilation control.
- The expansion joints of the profile must match the expansion joints of the panel.

- ↔ Horizontal dilation point
- ↕ Vertical dilation point
- ↕↔ Dilation point

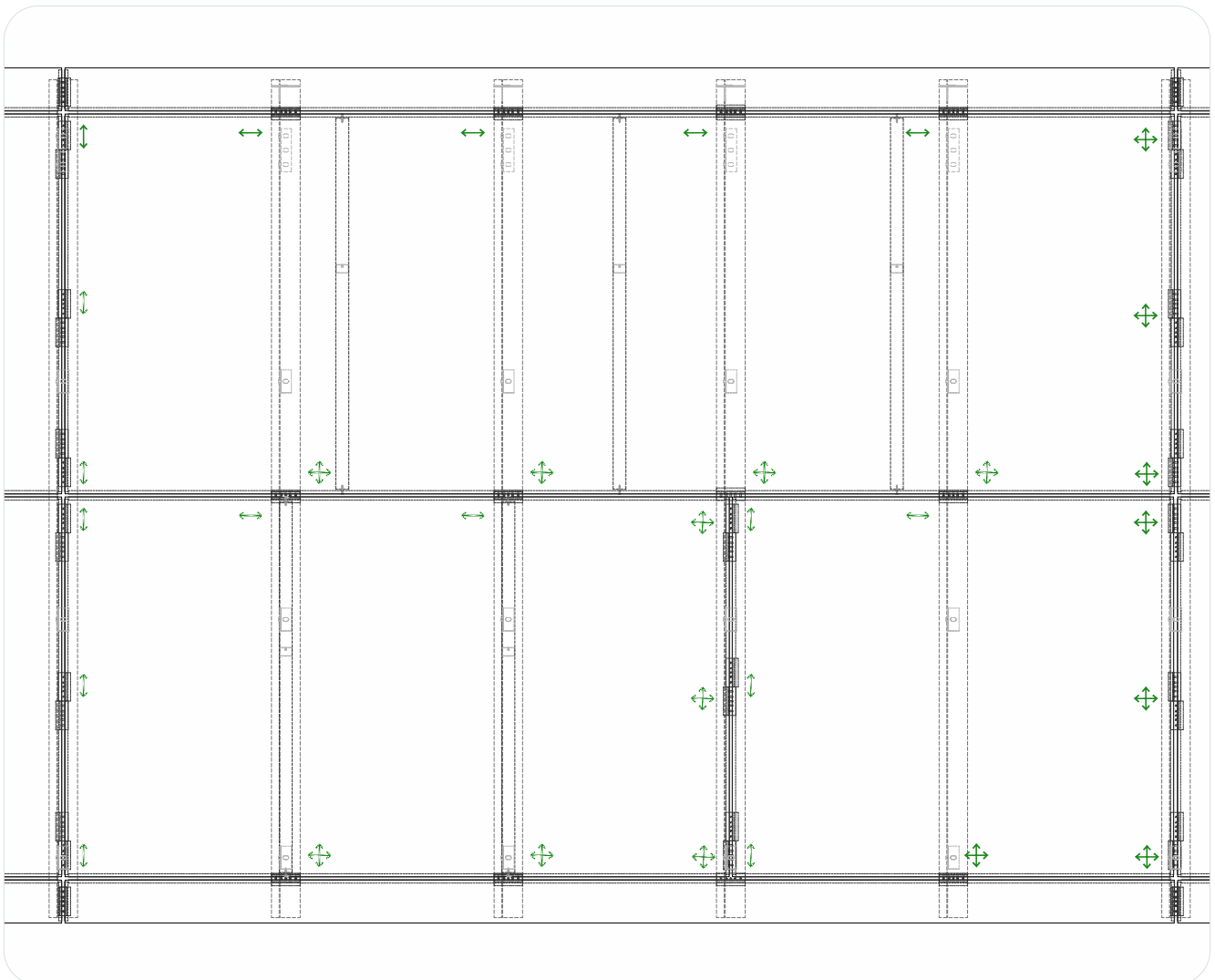

Dilations in the **Hidetech® LIGHT** system

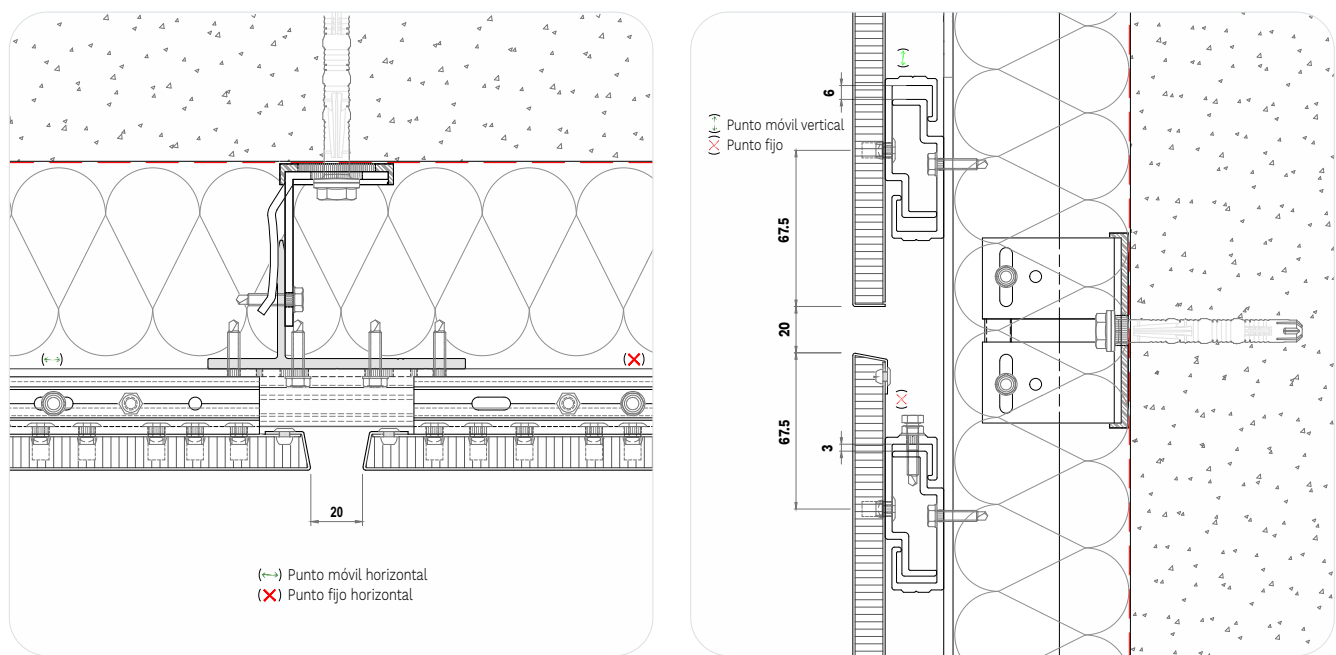

Dilations in the **Hidetech® PRO** system

## 14. Inspection and maintenance guidelines.

This recommendation covers procedures for cleaning and maintaining coated aluminium roof covering and wall cladding. The information contains recommended methods as an aid in establishing safe, sound cleaning and maintenance practices with respect to coated aluminium roof covering and wall cladding.

### 14.1. General Considerations

It is recommended that the building owner provide a qualified inspector who will see that the desired effect is being obtained with the use of sound cleaning and maintenance procedures. One inspection per year and associated cleaning of all areas is required for Limited Warranty coverage (cleaning and maintenance records should be kept and made available to **Alucoil®** if they are required).

Cleaning is vital in areas where industrial deposits have dulled the surface, where materials from construction processes have soiled the surface or where cleaner run-down from other surfaces should be removed. Local conditions as well as building location within a geographical area quite naturally have an effect on cleanliness.

#### Regular inspection and maintenance should consist of:

- Checking the condition of the sealants, fasteners and flashings to ensure water tightness.
- Examining local defects (e.g. scratches) that may cause early deterioration of the coating or corrosion of the substrate.
- Removing any blockage in gutters to avoid overflow or buildup.
- Removal of leaves, grass, mould and other objects and debris.
- Removal of dirt in areas of cladding not rinsed naturally by rainwater.
- Removal of graffiti or other marks.

Cleaning of coated aluminium may be scheduled with other cleaning. For example, glass and painted aluminium components can be cleaned at the same time. Cleaning is specifically required in areas of low rainfall or in industrialized areas. Foggy coastal regions with cycles of condensation and drying may tend to cause a build-up of atmospheric salts and dirt. In any climate, sheltered areas, such as overhangs, may become soiled due to insufficient rainwater rinsing. Thorough rinsing is especially important after cleaning of these sheltered areas. If automatic or pressure-based wall cleaning equipment is to be used on a building, a test should be made early in equipment design to ensure that the cleaning solutions, brushes, as well as the frequency of cleaning should be taken into consideration to ensure no detrimental effect on or to the coating. After completion of the building, special attention should be paid to fixings, damages to the coating, drilling swarf, pop rivet systems and general building debris. Construction soils, including concrete or mortar, etc. should be removed as soon as possible. The exact procedure for cleaning will vary depending on the nature and degree of soil. Try to restrict cleaning to mild weather. Cleaning should be done on the shaded side of the building or ideally on a mild, cloudy day. Method of cleaning, type of cleaner, etc. of one component of the building must be used with consideration for other components such as glass, sealant, painted surfaces, etc.



## 14.2. Cleaning.

### • Removal of light surface soil:

Removal of light surface soil may be accomplished in several ways. Some testing is recommended to determine the degree of cleaning actually necessary to accomplish the task. Ideally, an initial step of forceful water rinse from the top down is recommended prior to any cleaner application. Significant benefit is gained with some type of surface agitation. Low water volume with moderate pressure is much better than considerable volume with little pressure. Physical rubbing of the surface with soft, wet brushes, sponges or cloth is also helpful.

The simplest procedure would be to apply the water rinse with moderate pressure to dislodge the soil. If this does not remove the soil, then a concurrent water spray with brushing or sponging should be tested. If soil is still adhering after drying, then a mild detergent will be necessary. When a mild detergent (PH7) or mild soap is necessary for removal of soil, it should be used with brushing or sponging. The washing should be done with uniform pressure, cleaning first with a horizontal motion and then with a vertical motion. Apply cleaners only to an area that can be conveniently cleaned without changing position. The surface must be thoroughly rinsed with clean water. It may be necessary to sponge the surface while rinsing, particularly if cleaner is permitted to dry on the surface. The rinsed surface can be air dried or wiped dry with a chamois, squeegee or lint free cloth. Run down of cleaner (from any operation) to the lower portions of the building should be minimized and these areas should be rinsed as soon as and as long as necessary to reduce streaking etc. from unavoidable run down. Do not allow cleaning chemicals to collect on surfaces or to "puddle" on horizontal surfaces, crevices, etc.

These areas should be flushed with water and dried via air or wiped dry with a chamois, squeegee or lint free cloth.

Always clean coated surfaces down from top to bottom and follow with a thorough rinsing with clean water. (With one storey or low elevation buildings, it is recommended to clean from bottom up and rinse from top down). To avoid water stain, the surface should be wiped.

### • Cleaning of medium to heavy soil:

Some type of mild solvent such as mineral spirits may be used to remove grease, sealant or caulking compounds. Stronger solvent or solvent containing cleaners may have a deleterious or softening effect on coatings; accordingly, great care should be taken. To prevent harm to the finish, these types of solvent or emulsion cleaners should be soap tested and preferably the coating manufacturer should be consulted. Care should be taken to assure that no marring of the surface is taking place in this manner since this could cause an undesirable appearance at certain viewing angles. Cleaners of this type are usually applied with a clean cloth and removed with a cloth. Remaining residue should be washed with mild soap and rinsed with water. Use solvent cleaners sparingly. It may be possible for solvents to extract materials from sealants which could stain the painted surface or could prove harmful to sealants; therefore, possible adverse effects must be considered. Test clean a small area first.

• If cleaning of a heavy surface soil has been postponed or in cases of tenacious soil, stubborn stains, etc., then a more aggressive cleaner and technique may be required. Cleaner and technique should be matched to the soil and the painted finish. Some local manual cleaning may be needed at this point.

Always follow the recommendations of the cleaner manufacturer as to proper cleaner and concentration. Test clean a small area first. Cleaners should not be used indiscriminately. Do not use excessive, abrasive rubbings as such may alter surface texture or may impart a "shine" to the surface. Concrete spillage that has dried on the coated surface may become quite difficult to remove. Special cleaners and/or vigorous rubbing with non-abrasive brushes or plastic scrapers may be necessary. Diluted solutions of Muriatic Acid (under 10%) may be effective in removing dried concrete stains; however, a small test clean area should be tried first, and proper handling precautions must be exercised for safety reasons.

Never mix cleaners. Doing so may be ineffective, and worse, very dangerous. For example, mixing chlorine containing materials, such as bleaches, with other cleaning compounds containing ammonia can cause poisonous gas emissions. Always rinse the coated material after removal of heavy surface soil.

## **Summary of general cleaning tips**

- Overcleaning or excessive rubbing can do more harm than good.
- Strong solvents or strong cleaner concentrations can cause damage to painted surfaces.
- Avoid abrasive cleaners. Do not use household cleaners that contain abrasives on painted surfaces.
- Abrasive materials such as steel wool, abrasive brushes, etc. can wear and harm finishes.
- Avoid drips and splashes. Remove run downs as quickly as possible.
- Cleaning should be done in shade at moderate temperatures. Avoid temperature extremes. Heat accelerates chemical reactions and may evaporate water from solution. Extremely low temperature may give poor cleaning effects. Cleaning under adverse conditions may result in streaking or staining.
- Do not substitute a heavy duty cleaner for a frequently used mild cleaner.
- Do not scour coated surfaces.
- Never use paint removers, aggressive alkaline, acid or abrasive cleaners, phosphate or highly alkaline or highly acid cleaners.
- Follow manufacturers recommendations for mixing and diluting cleaners.
- Never mix cleaners.
- To prevent marring, make sure cleaning sponges, cloth etc. are grit free.
- Always test clean small surface.
- "An ounce of prevention is worth a pound of cure".

#### 14.3. Repair.

Damage may be found on the surface of the coating when cleaning or otherwise maintaining the coated roof covering or wall cladding. Paint repair should be restricted to small areas (max. 5.0 m<sup>2</sup>).

¡Any significant repair work should be informed **Alucoil®**!

##### Execution when no corrosion is found:

- The damaged surface should be washed and dried as described above.
- A recommended touch-up paint should be applied for protective and aesthetic reasons.

##### Execution with small corrosion defects:

- Remove the dust by abrading, scraping, and sand blasting to the bare material.
- Degrease the complete surface.
- Clean and dry the surface (as described above) before applying a repair paint system (primer and top coat) recommended by the material supplier.

#### 14.4. Re painted.

If it is deemed necessary to re-paint or reclad large surfaces, contact **Alucoil®** before execution.

Investigating the economic feasibility of over-painting the existing structure or replacing the coated sheets is recommended. In case of any questions about overpainting please contact us. Using non-compatible systems of repair paints and original coated surfaces might cause undesired effects.





## ONLY EUROPE (EUROCODE)

### 12. Wind loads and pressure

#### Basis for calculation

The wind speed and the velocity pressure are composed of a mean and a fluctuating component. The mean wind velocity  $V_m$  should be determined from the basic wind velocity  $V_b$  which depends on the wind climate and the height variation of the wind determined from the terrain roughness and orography. The fluctuating component of the wind is represented by the turbulence intensity.

#### Basic values

The basic wind velocity shall be calculated from expression  $V_b = C_{dir} \cdot C_{season} \cdot V_{b,0}$

$V_b$  is the basic wind velocity

$V_{b,0}$  is the fundamental value of the basic wind velocity

$C_{dir}$  is the directional factor

$C_{season}$  is the season factor

#### Mean wind (variation with height)

The mean wind velocity  $V_m(z)$  at a height  $z$  above the terrain depends on the terrain roughness and orography and on the basic wind velocity,  $V_b$ .

$$V_m(z) = C_r(z) \cdot C_o(z) \cdot V_b$$

$C_r(z)$  is the roughness factor

$C_o(z)$  is the orography factor, taken as 1,0 unless otherwise specified.

#### Terrain roughness

The roughness factor,  $C_r(z)$ , accounts for the variability of the mean wind velocity at the site of the structure due to:

- 1.- The height above ground level.
- 2.- The ground roughness of the terrain upwind of the structure in the wind direction considered.

$$C_r(z) = k_r \cdot \ln(z/z_0) \text{ for } z_{min} \leq z \leq z_{max}$$

$$C_r(z) = C_r(z_{min}) \text{ for } z \leq z_{min}$$

$z_0$  is the roughness length

$k_r$  is the terrain factor depending on the roughness length  $z_0$  calculated using  $k_r = 0,19 (z_0 / z_{0,11})^{0,07}$

$z_{0,11} = 0,05m$  (terrain category II, table 1)

$z_{min}$  is the minimum height defined in table 1

$z_{max}$  is to be taken as 200 m

External pressure coefficients for vertical walls

Zone	A		B		C		D		E	
	$C_{pe,10}$	$C_{pe,1}$	$C_{pe,10}$	$C_{pe,1}$	$C_{pe,10}$	$C_{pe,1}$	$C_{pe,10}$	$C_{pe,1}$	$C_{pe,10}$	$C_{pe,1}$
h/d										
5	-1,2	-1,4	-0,8	-1,1	-0,5		+0,8	+1,0		-0,7
1	-1,2	-1,4	-0,8	-1,1	-0,5		+0,8	+1,0		-0,5
≤0,25	-1,2	-1,4	-0,8	-1,1	-0,5		+0,7	+1,0		-0,3

#### TERRAIN CATEGORY

	$z_0$ m	$z_{min}$ m
<b>0</b> Sea or coastal area exposed to the open sea.	0,003	1
<b>I</b> Lakes or flat and horizontal area with negligible vegetation and without obstacles.	0,01	1
<b>II</b> Area with low vegetation such as grass and isolated obstacles (trees, buildings) with separations of at least 20 obstacle heights.	0,05	2
<b>III</b> Area with regular cover of vegetation or buildings or with isolated obstacles with separations of maximum 20 obstacle heights (such as villages, suburban terrain, permanent forest).	0,3	5
<b>IV</b> Area in which at least 15% of the surface is covered with buildings and their average height exceeds 15m.	1,0	10

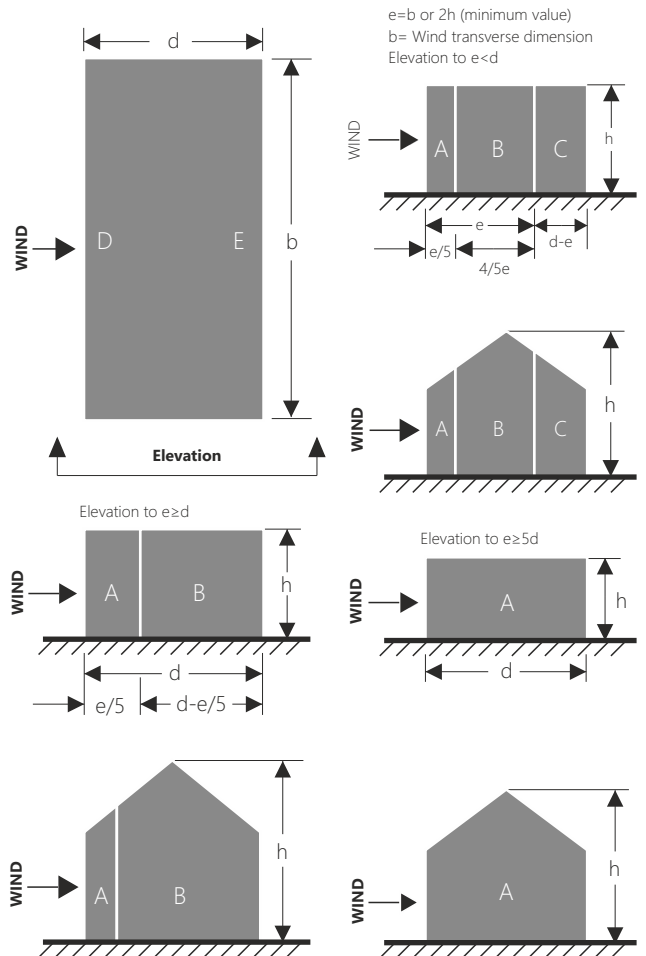

#### Peak velocity pressure $q_p(z) = C_r(z) \cdot q_b$

Illustration of the exposure factor  $C_r(z)$  for  $C_0=1.0$ ,  $k_r=1.0$

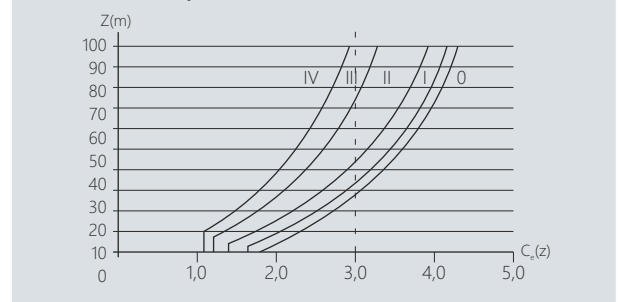

#### Wind pressure on surfaces $W_e = q_p(z_e) \cdot C_{pe}$

$z_e$  is the reference height for the external pressure

$C_{pe}$  is the pressure coefficient for the external pressure

The figure is based on the following: for  $1m^2 < A < 10m^2$

$$C_{pe} = C_{pe,1} (C_{pe,1} - C_{pe,10}) \log_{10} A$$

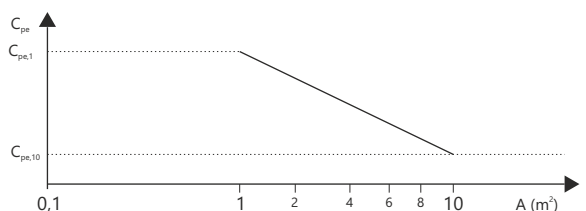

## ONLY IN SPAIN (CTE)

### 12. Acción del viento (DB SE-AE, CTE ESPAÑA)

La distribución y el valor de las cargas que ejerce el viento sobre una zona de la fachada de un edificio dependen de la forma y de las dimensiones de la construcción, de la altura, posición y dimensión del elemento de estudio, del entorno que rodea al edificio y de la zona eólica en que se encuentra.

La acción del viento (que se considera siempre perpendicular a cualquier superficie plana sobre la que actúe) viene definida por la siguiente fórmula:  $q_e = q_b \cdot c_e \cdot c_{pe}$ , siendo:

a)  $q_b$ : Presión dinámica del viento.

De forma simplificada se puede adoptar el valor de 0,5 kPa en cualquier punto de España, pero existe un mapa con tres zonas diferenciadas de velocidad básica del viento.

- Zona A: 26 m/s ( $q_b=422,500$  Pa)
- Zona B: 27 m/s ( $q_b=455,625$  Pa)
- Zona C: 29 m/s ( $q_b=525,625$  Pa)

b)  $c_e$ : En España existe una tabla con diferentes coeficientes de exposición para cada tipo de entorno, diferenciando claramente 5 grados de aspereza:

TABLA 1: Valores del coeficiente de exposición  $C_e$  (hasta 30 m).

Grado de aspereza del entorno	ALTURA DEL PUNTO CONSIDERADO (m)							
	3	6	9	12	15	18	24	30
<b>I.</b> Borde del mar o de un lago, con una superficie de agua en la dirección del viento de al menos 5km de longitud.	2,4	2,7	3,0	3,1	3,3	3,4	3,5	3,7
<b>II.</b> Terreno rural llano sin obstáculos ni arbolado de importancia.	2,1	2,5	2,7	2,9	3,0	3,1	3,3	3,53
<b>III.</b> Zona rural accidentada o llana con algunos obstáculos aislados, como árboles o construcciones pequeñas.	1,6	2,0	2,3	2,5	2,6	2,7	2,9	,1
<b>IV.</b> Zona urbana en general, industrial o forestal.	1,3	1,4	1,7	1,9	2,1	2,2	2,4	2,6
<b>V.</b> Centro de negocios de grandes ciudades, con profusión de edificios en altura.	1,2	1,2	1,2	1,4	1,5	1,6	1,9	2,0

c)  $c_p$ : Coeficiente eólico o de presión. Depende de la forma del edificio, de la posición de elemento considerado y de su área de

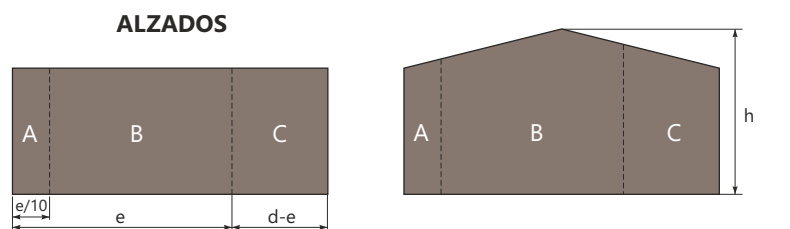

### PLANTA



TABLA 2: coeficientes eólicos para edificios de paramentos verticales en edificios de volumen prismático

A (m <sup>2</sup> )	h/d	Zona (según figura), -45° < θ < 45°				
		A	B	C	D	E
≥ 10	5	-1,2	-0,8	-0,5	0,8	-0,7
	1	"	"	"	"	-0,5
	≤ 0,25	"	"	"	0,7	-0,3
5	5	-1,3	-0,9	-0,5	0,9	-0,7
	1	"	"	"	"	-0,5
	≤ 0,25	"	"	"	0,8	-0,3
2	5	-1,3	-1,0	-0,5	0,9	-0,7
	1	"	"	"	"	-0,5
	≤ 0,25	"	"	"	0,7	-0,3
≤ 1	5	-1,4	-1,1	-0,5	1,0	-0,7
	1	"	"	"	"	-0,5
	≤ 0,25	"	"	"	"	-0,3



## 16. Iarcoring® A2 6 mm panels. Hidotech® LIGHT installation system for cassettes.

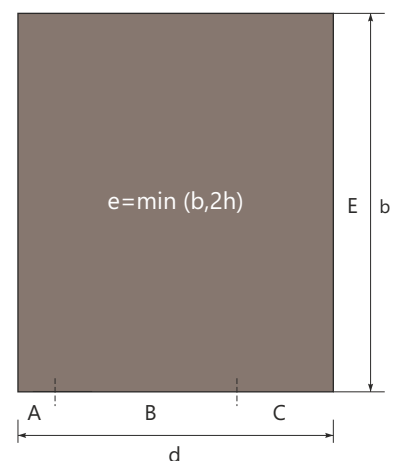

### a) Machining of the Iarcoring® A2 6 mm panel for installation with the Hidotech® LIGHT system.

The **Hidotech® LIGHT** allows the installation of **Iarcoring® A2 6 mm** panels transformed into trays by means of cuts and milling made in the panel. Subsequently, its sealed perimeter with a profile through which some clips slide that will serve to fix the cassette on the vertical profiles.

Scheme of the machining and shaping of the **Iarcoring® A2 6 mm** cassettes to be installed with the **Hidotech® LIGHT** system.

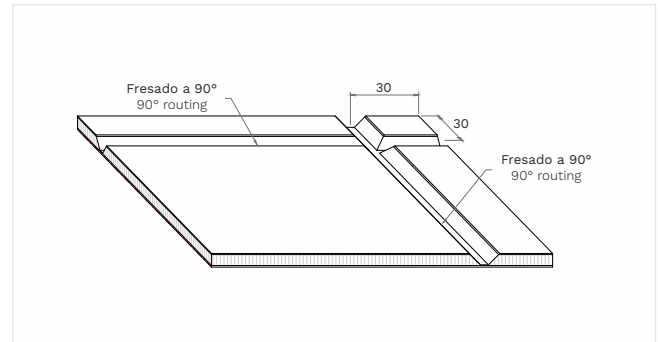
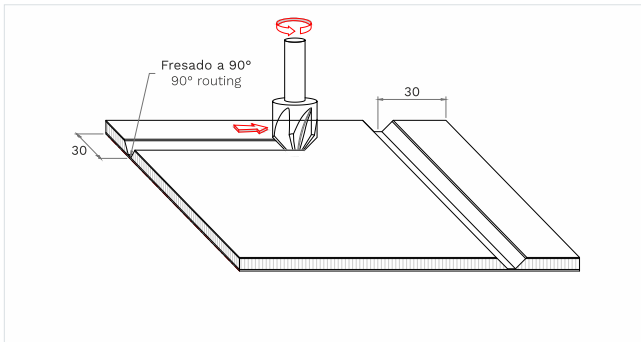

Routing of the panel around the four sides. Distance between panel edge and routing center should be 30 mm.

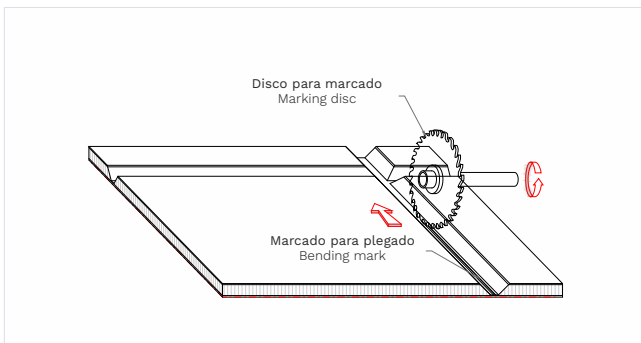

To achieve an accurate 90° bending, it is necessary to mark the middle of the lower side of the routing.

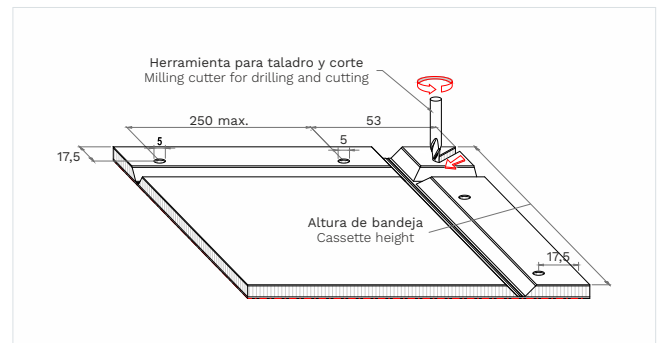

Cutting and drilling in the panel sides to shape the cassette.

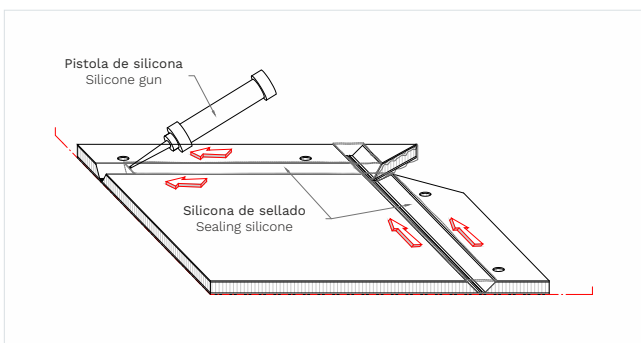

Sealing silicone of the panel.

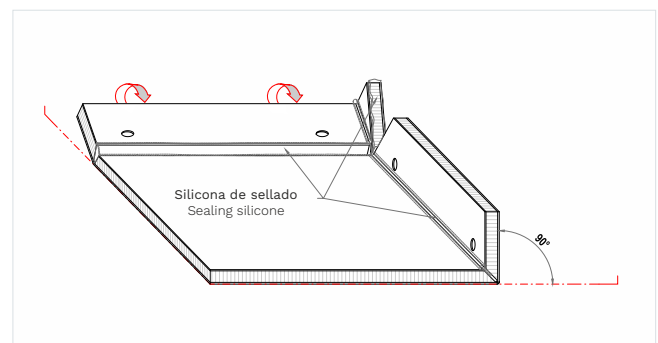

Bending to 90° of the edges.



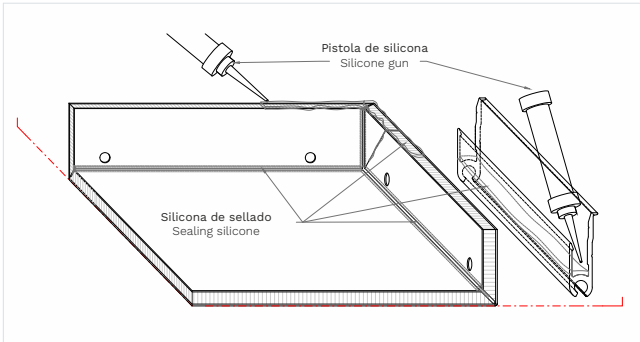

Sealing silicone is also applied to cassette corners and the inside of the LT-4 profiles along its entire length.

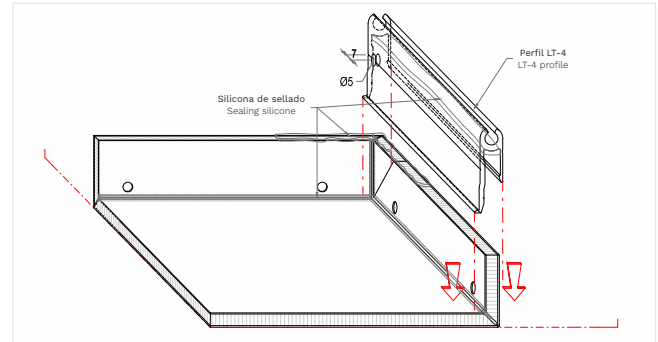

Placement to the LT-4 profile. Before a drill should be done in both sides of the profile.

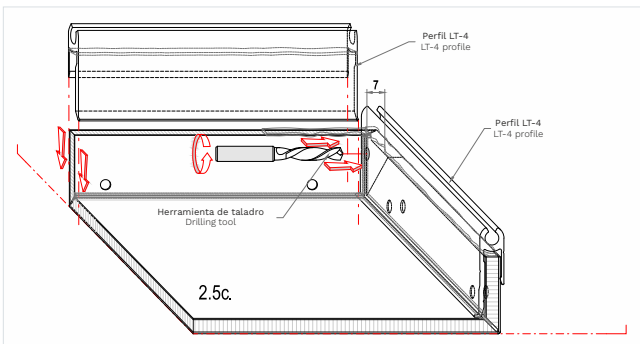

Drilling of the panel through its internal face to fix in the panel of the waterproofing rivet.

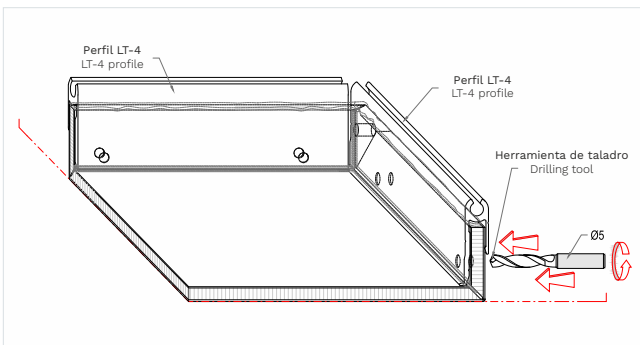
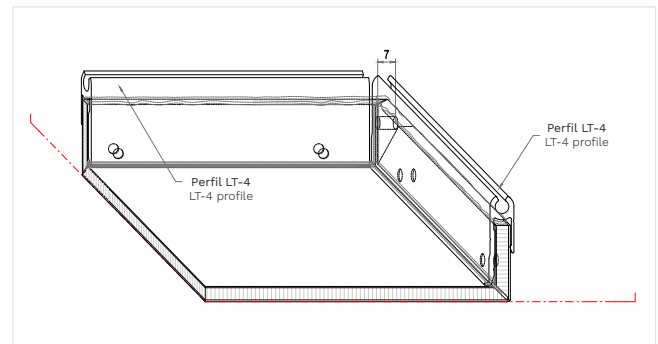

Drilling of the panel through its external face to fix in the panel of the standard rivet.

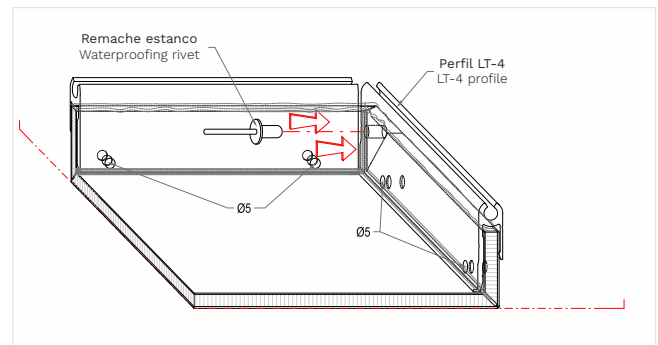

Fixing of the waterproofing rivets.

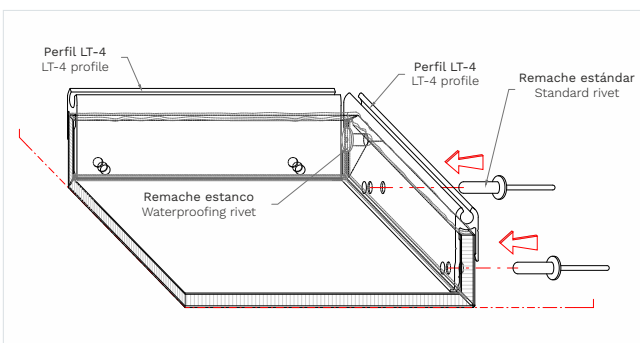

Fixing of the standard rivets.

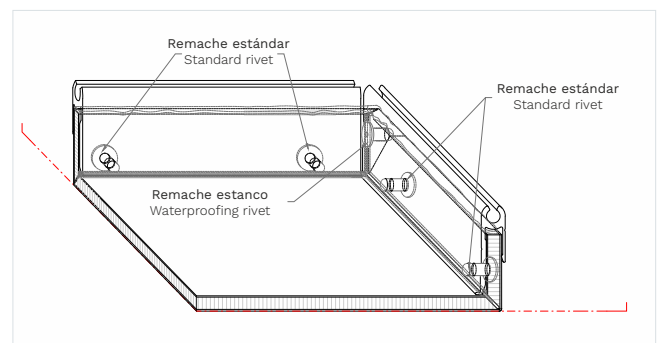

Cassette finished and ready to install with **Hidotech® LIGHT** installation system.



**b) Machining specifications CNC (data base on tools and machinery used in Alucoil® for other conditions see the technical characteristics of the tool supplier).**

The cutting and routing of larcore® A2 panels should be done in machines CNC for a perfect finish, and then instalation.

**PANEL CUT.**

Cutting tolerance: size requested +/- 1 mm.

Tool D.8 mm of 1 lip. Hard metal.

- a) Maximum:  $V_{r.p.m.}$ : 12000 / Advance: 8 m/min.
- b) Standard:  $V_{r.p.m.}$ : 10000 / Advance: 8 m/min.
- c) Minimum:  $V_{r.p.m.}$ : 8000 / Advance: 7 m/min.

Disc D.300x3.2 Z96. Speed steel.

- a) Speed 5000 r.p.m.
- b) Advance: 20 m/min.

**ROUTING FOR PANEL FOLDING.**

Tolerances between routing: 1 mm.

Disc D.120 mm. Hard metal.

- a) Maximum:  $V_{r.p.m.}$ : 6000 / Advance: 20 m/min.
- b) Standard:  $V_{r.p.m.}$ : 5000 / Advance: 20 m/min.
- c) Minimum:  $V_{r.p.m.}$ : 3000 / Advance: 15 m/min.

Tool "V" 45° D.12-45 mm hard metal (2/3 lips).

- a) Maximum:  $V_{r.p.m.}$ : 10000 / Advance: 10 m/min.
- b) Standard:  $V_{r.p.m.}$ : 8000 / Advance: 7 m/min.
- c) Minimum:  $V_{r.p.m.}$ : 5000 / Advance: 4 m/min

- A: 5mm
- B: (6-8-10-14-15-20)mm
- C: 0,5 mm / 0,7 mm / 1 mm
- D: 0,7 mm / 1 mm

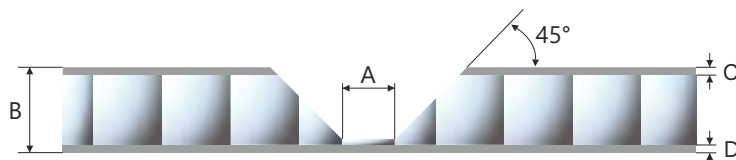

**IMPORTANT:**

All processing jobs must be done using protection gloves and security goggles to avoid wounds or injures by shavings. All processing jobs of **larcore® A2** must be done with the protective plastic film to avoid damages and at temperatures above 10°C on coated surface. The plastic film must remain until all processing jobs have been finished.



**c) Hidetech® LIGHT installation system development by Alucoil®.**

**larcore® A2 6 mm panels.**

**Hidetech® LIGHT installation system of the cassettes.**

It would be customer responsibility to verify that any product supplied complies with applicable regulations related to product installation, and, in particular, with any regulations regarding fire resistance and fire reaction.

The information and measures contained in this document are for conceptual and theoretical use only. **Alucoil®** shall have no responsibility for these products usage and installation.

The inappropriate use and total or partial reproduction is forbidden, except if expressly authorized by **Alucoil® S.A.U.**

Panel design, transformation and transformation and installation are the sole responsibility of the purchaser.

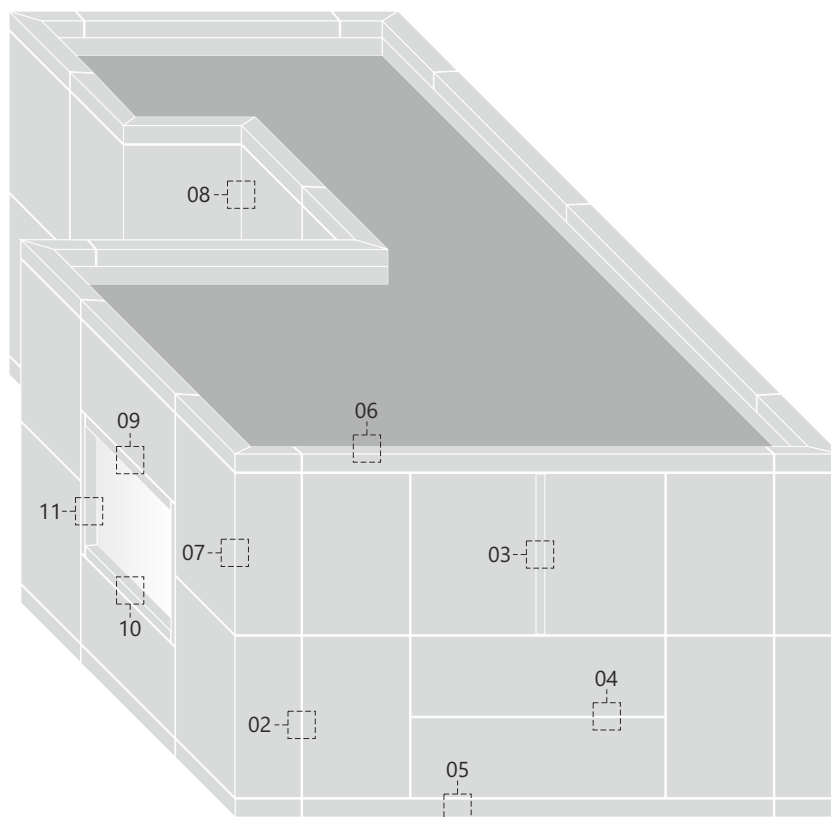

- 01.** Outside elevation
- 02.** Vertical joint
- 03.** LC-RH Stiffener
- 04.** Horizontal joint
- 05.** Façade starting
- 06.** Parapet detail
- 07.** External corner
- 08.** Internal corner
- 09.** Window head detail
- 10.** Window sill detail
- 11.** Window jamb detail



**Hidetech® LIGHT installation system for Iarcoring® A2 6 mm cassettes.**

**System accessories**

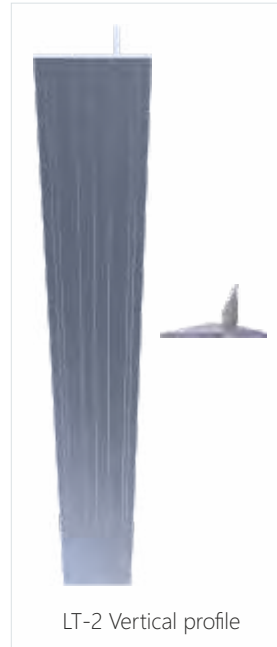

**How to shape the cassette?.**

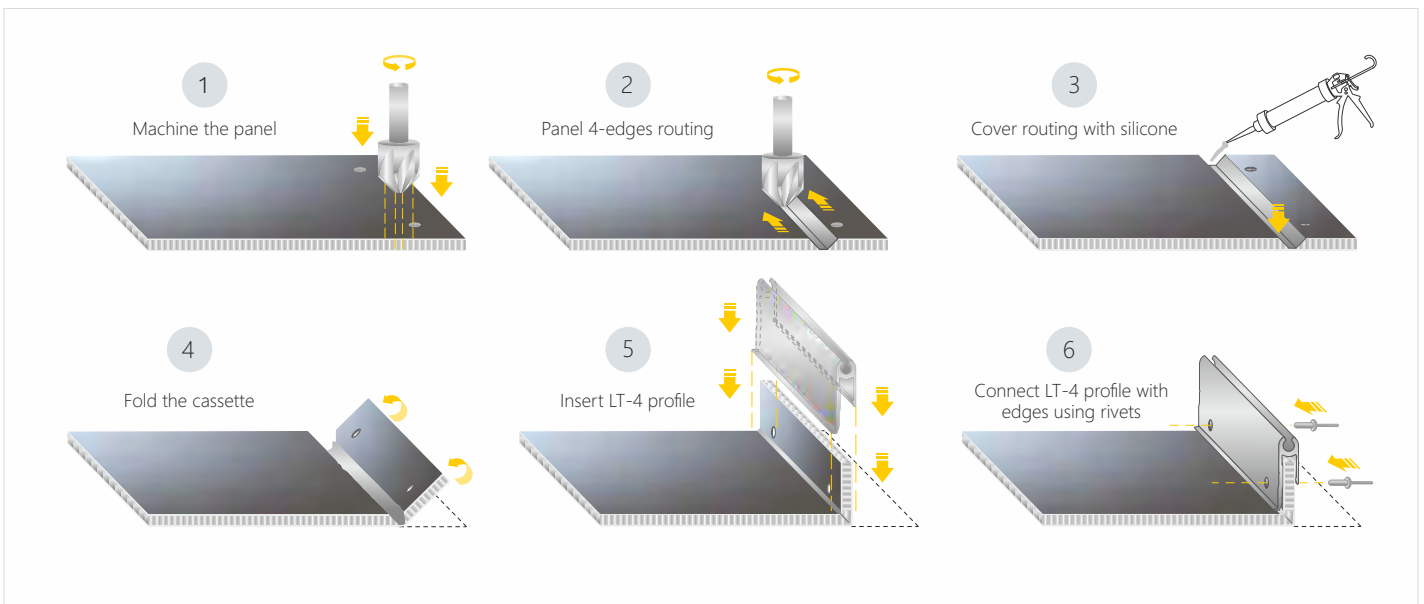

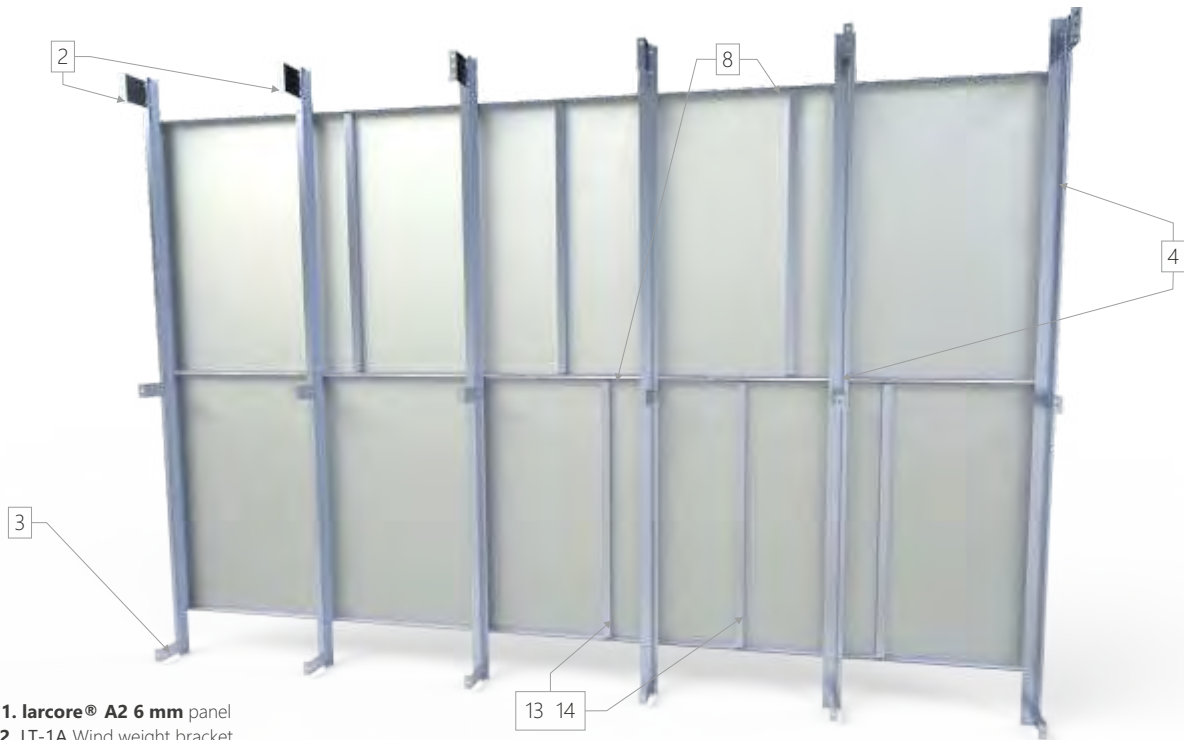

- 1. larcore® A2 6 mm panel
- 2. LT-1A Wind weight bracket
- 3. LT-1B Wind bracket
- 4. LT-2 Vertical profile
- 5. LT-31M Mobile clip (right/bottom)
- 6. LT-31F Fixed clip (top/left)
- 7. LT-32M short mobile clip
- 8. LT-4 perimetral profile
- 9. Silicone
- 10. Waterproofing rivet
- 11. Standard rivet
- 12. EJOT TORX T25 special screw
- 13. LC-RH stiffener
- 14. Sika Tack Panel 50 adhesive
- 15. INDEX flat head screw

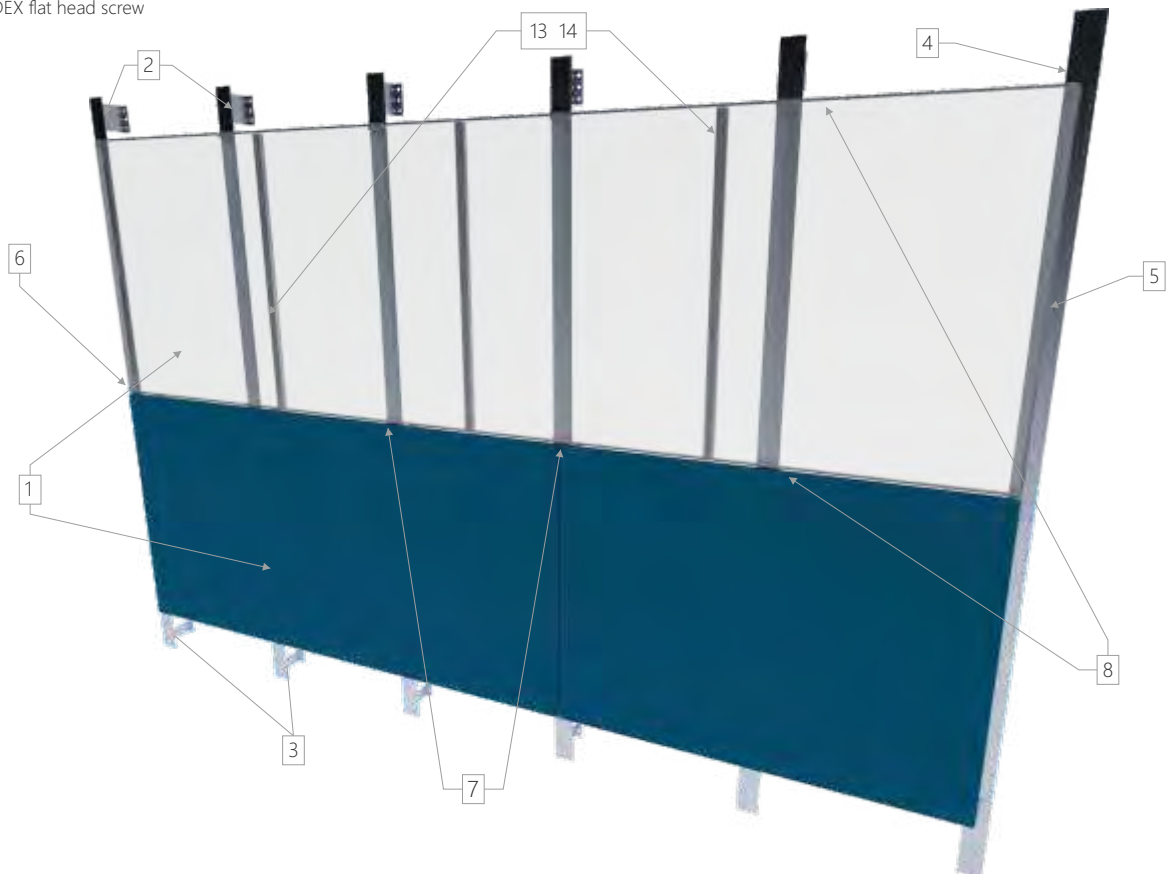
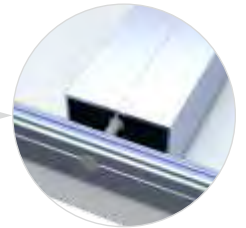



**Hidotech® LIGHT installation system "Iarc core® A2 6 mm cassettes".**

01. Outside elevation.

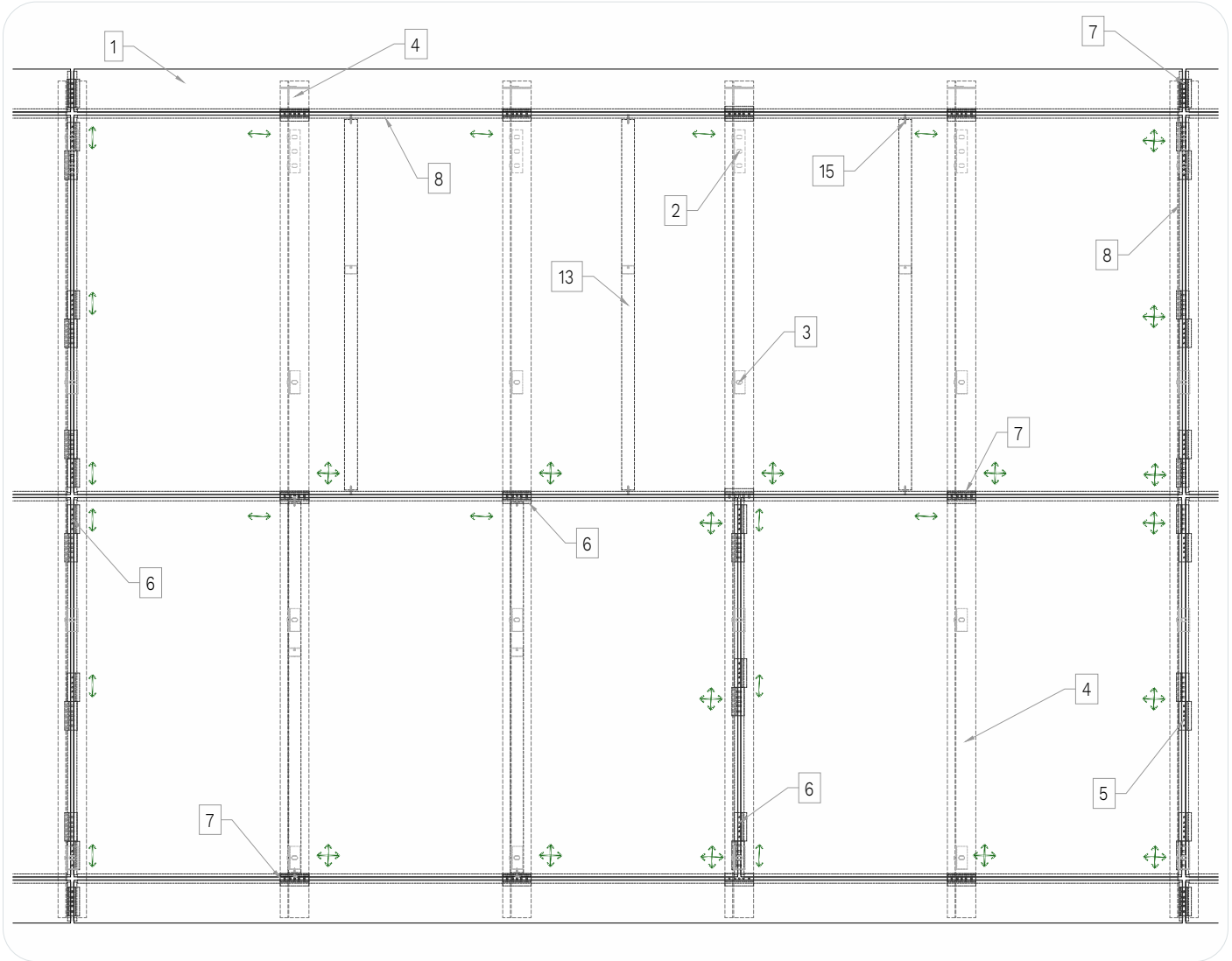

- ↔ Horizontal dilation point
- ↑↓ Vertical dilation point
- ↕ Dilation point

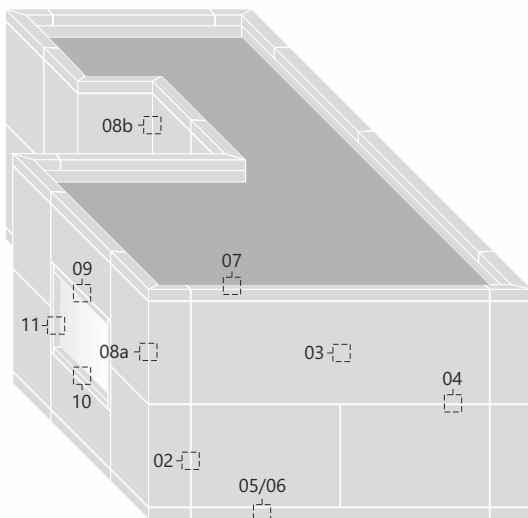

- 1.** Iarc core® A2 6 mm panel
- 2.** LT-1A wind-weight bracket
- 3.** LT-1B wind bracket
- 4.** LT-2 vertical profile
- 5.** LT-31M tall mobile clip
- 6.** LT-31F tall fixed clip
- 7.** LT-32M short mobile clip
- 8.** LT-4 perimetral profile
- 9.** DOWSIL™ 7092 Adhesive and Sealant silicone
- 10.** Ø4.8x8mm Alu/A2 waterproofing rivet
- 11.** Ø4.8x14mm Alu/A2 standard rivet
- 12.** EJOT JT4-ZT4 Ø4.8x25mm A2 TORX® T25
- 13.** LC-RH intermediate stiffener
- 14.** SikaTack Panel 50 adhesive
- 15.** INDEX Ø4.2x32mm A2/50 flat head screw
- 16.** LT-0A/B thermal break
- 17.** 2-3mm aluminum plate

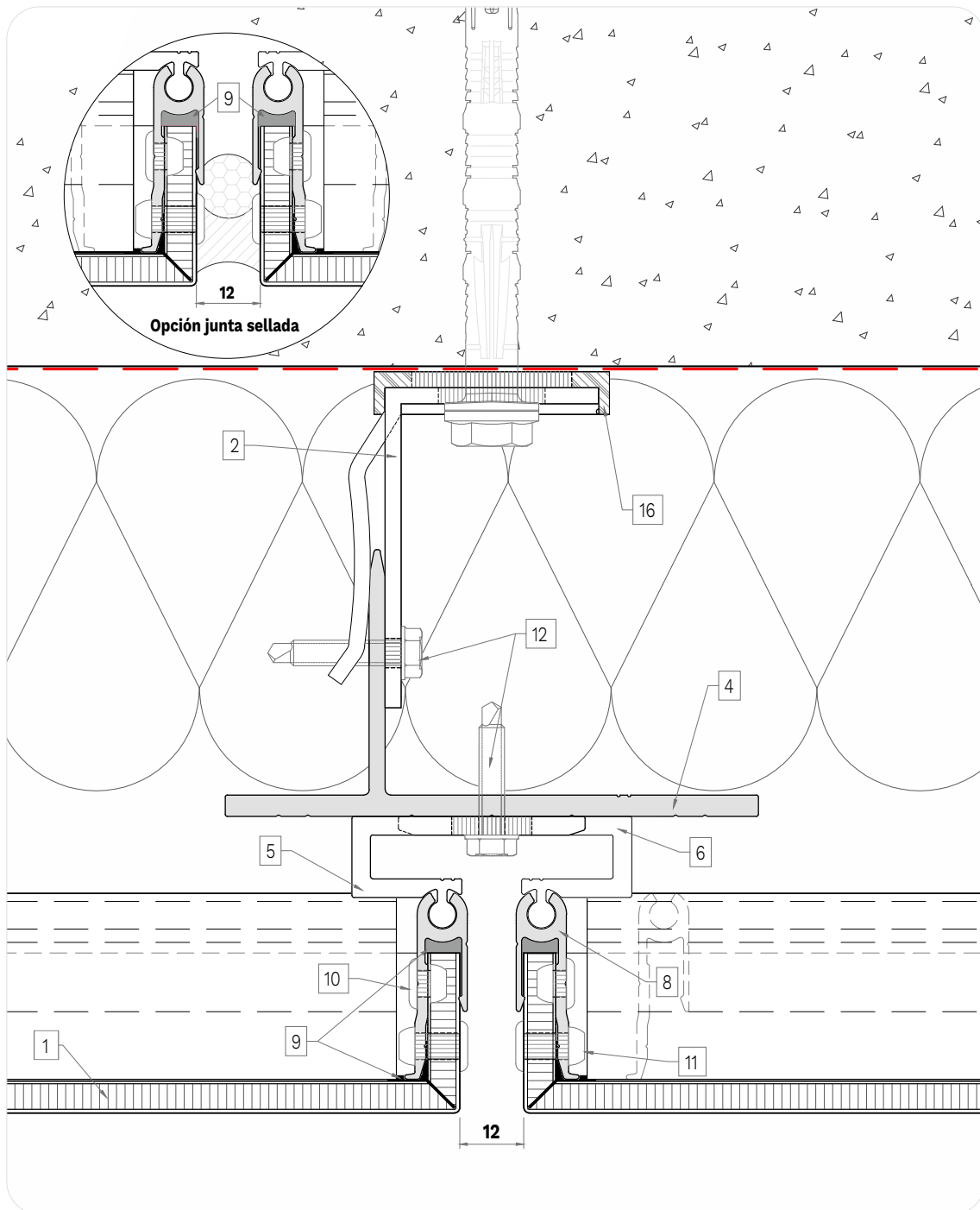

## 02. Vertical joint

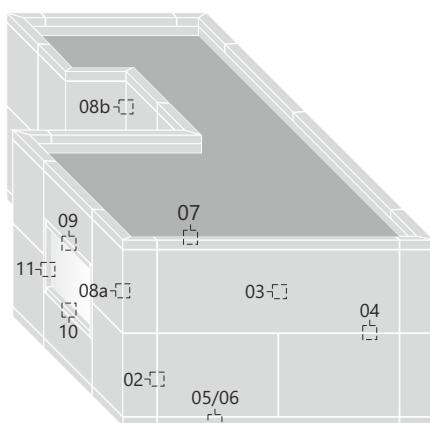

1. larcore® A2 6 mm panel
2. LT-1A wind-weight bracket
3. LT-1B wind bracket
4. LT-2 vertical profile
5. LT-31M tall mobile clip
6. LT-31F tall fixed clip
7. LT-32M short mobile clip
8. LT-4 perimetral profile
9. DOWSIL™ 7092 Adhesive and Sealant silicone
10. Ø4.8x8mm Alu/A2 waterproofing rivet
11. Ø4.8x14mm Alu/A2 standard rivet
12. EJOT JT4-ZT4 Ø4.8x25mm A2 TORX® T25
13. LC-RH intermediate stiffener
14. SikaTack Panel 50 adhesive
15. INDEX Ø4.2x32mm A2/50 flat head screw
16. LT-0A/B thermal break
17. 2-3mm aluminum plate

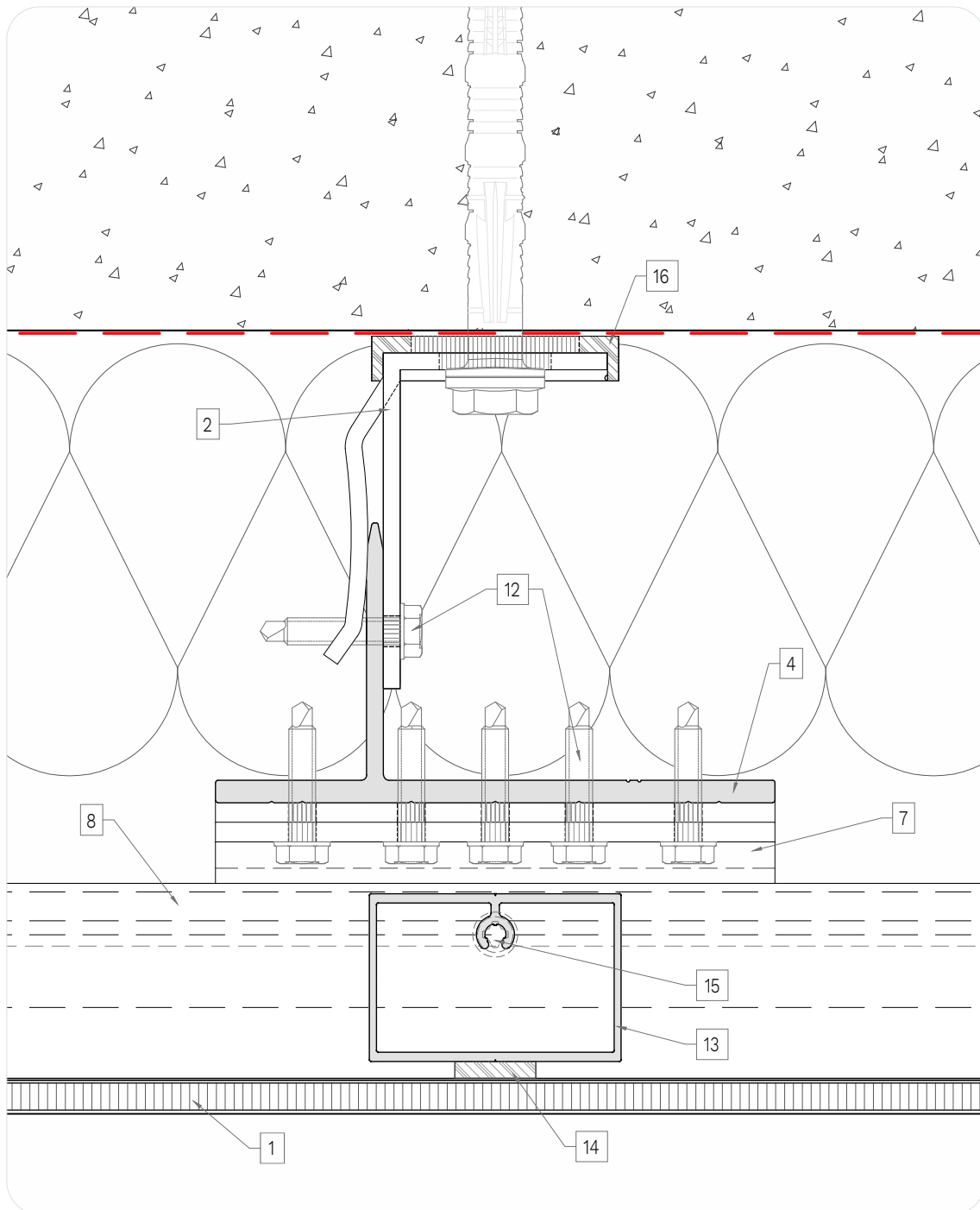

### 03. LC-RH stiffener

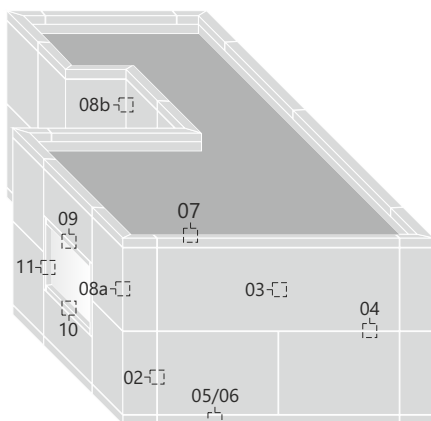

1. Iarc core® A2 6 mm panel
2. LT-1A wind-weight bracket
3. LT-1B wind bracket
4. LT-2 vertical profile
5. LT-31M tall mobile clip
6. LT-31F tall fixed clip
7. LT-32M short mobile clip
8. LT-4 perimeteral profile
9. DOWSIL™ 7092 Adhesive and Sealant silicone
10. Ø4.8x8mm Alu/A2 waterproofing rivet
11. Ø4.8x14mm Alu/A2 standard rivet
12. EJOT JT4-ZT4 Ø4.8x25mm A2 TORX® T25
13. LC-RH intermediate stiffener
14. SikaTack Panel 50 adhesive
15. INDEX Ø4.2x32mm A2/50 flat head screw
16. LT-0A/B thermal break
17. 2-3mm aluminum plate



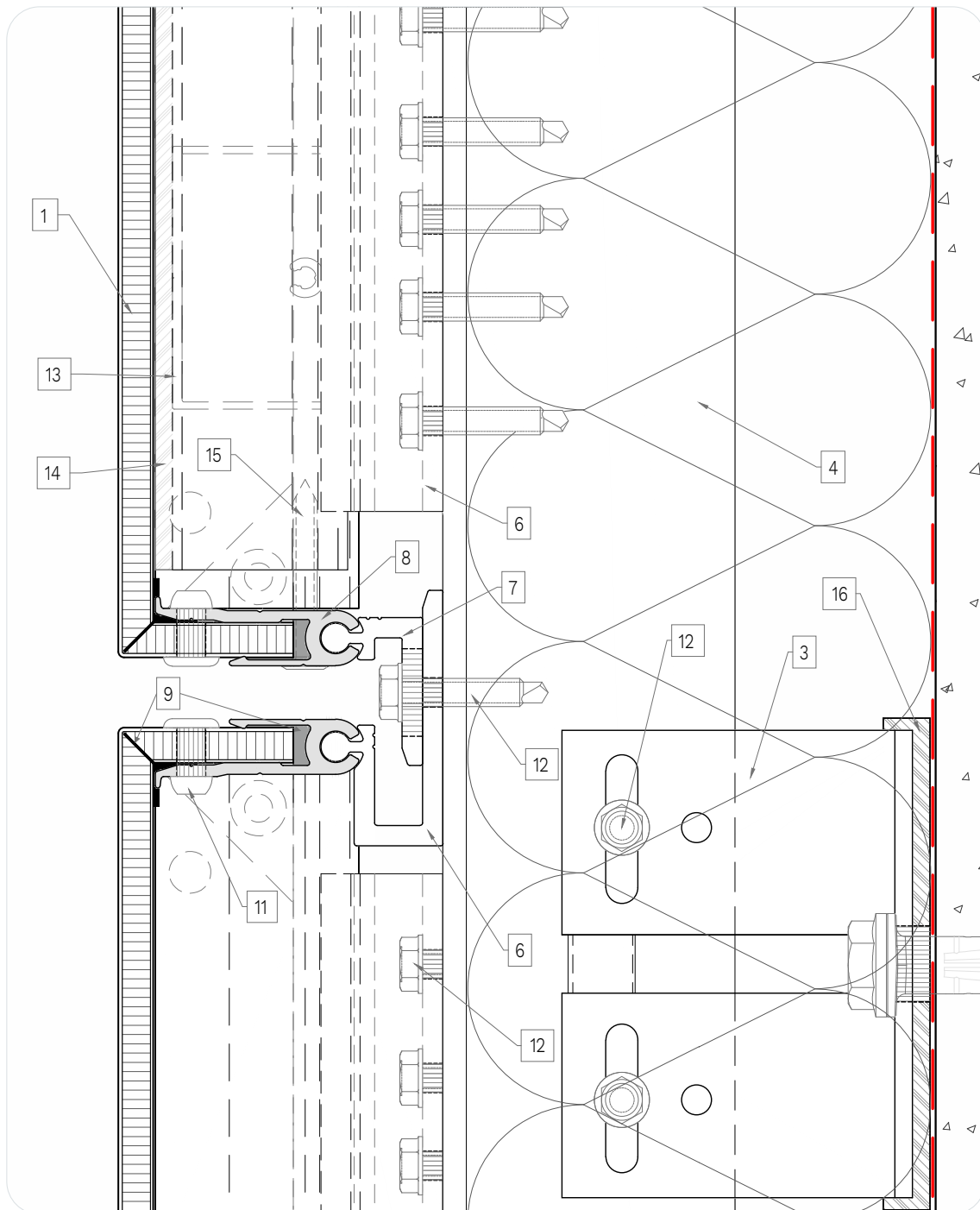

#### 04. Horizontal joint

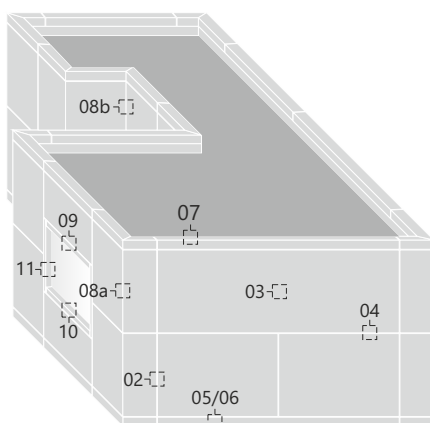

- 1. larcore® A2 6 mm panel
- 2. LT-1A wind-weight bracket
- 3. LT-1B wind bracket
- 4. LT-2 vertical profile
- 5. LT-31M tall mobile clip
- 6. LT-31F tall fixed clip
- 7. LT-32M short mobile clip
- 8. LT-4 perimetral profile
- 9. DOWSIL™ 7092 Adhesive and Sealant silicone
- 10. Ø4.8x8mm Alu/A2 waterproofing rivet
- 11. Ø4.8x14mm Alu/A2 standard rivet
- 12. EJOT JT4-ZT4 Ø4.8x25mm A2 TORX® T25
- 13. LC-RH intermediate stiffener
- 14. SikaTack Panel 50 adhesive
- 15. INDEX Ø4.2x32mm A2/50 flat head screw
- 16. LT-0A/B thermal break
- 17. 2-3mm aluminum plate

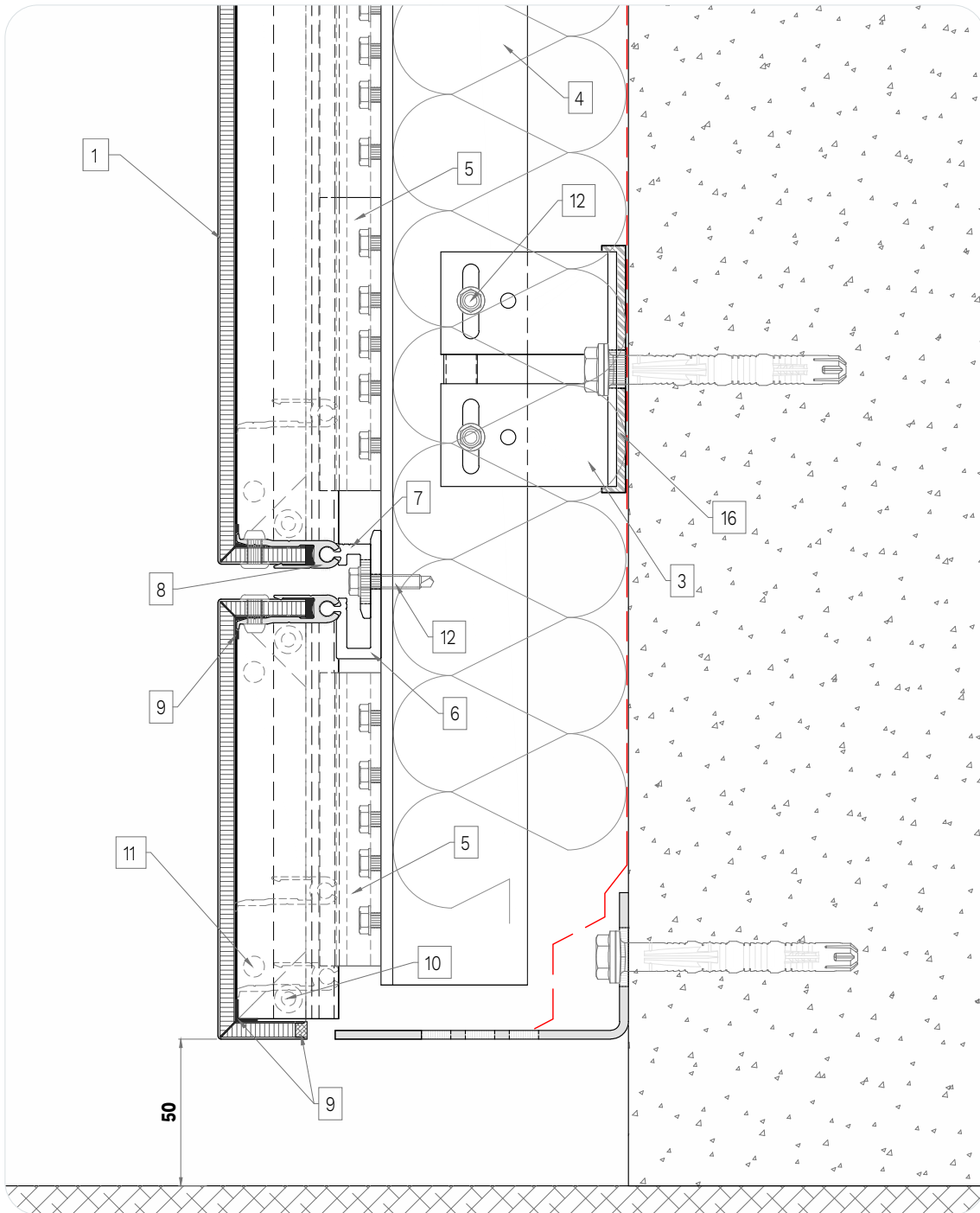

**05a. Façade starting I**

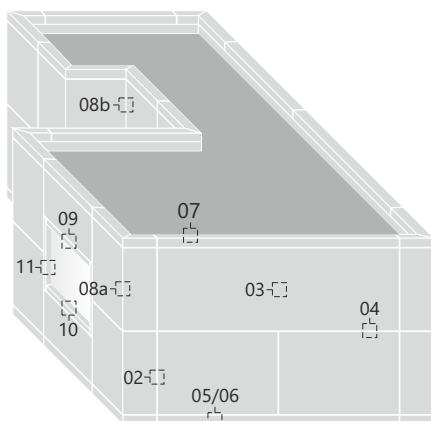

1. Iarcore® A2 6 mm panel
2. LT-1A wind-weight bracket
3. LT-1B wind bracket
4. LT-2 vertical profile
5. LT-31M tall mobile clip
6. LT-31F tall fixed clip
7. LT-32M short mobile clip
8. LT-4 perimetral profile
9. DOWSIL™ 7092 Adhesive and Sealant silicone
10. Ø4.8x8mm Alu/A2 waterproofing rivet
11. Ø4.8x14mm Alu/A2 standard rivet
12. EJOT JT4-ZT4 Ø4.8x25mm A2 TORX® T25
13. LC-RH intermediate stiffener
14. SikaTack Panel 50 adhesive
15. INDEX Ø4.2x32mm A2/50 flat head screw
16. LT-0A/B thermal break
17. 2-3mm aluminum plate

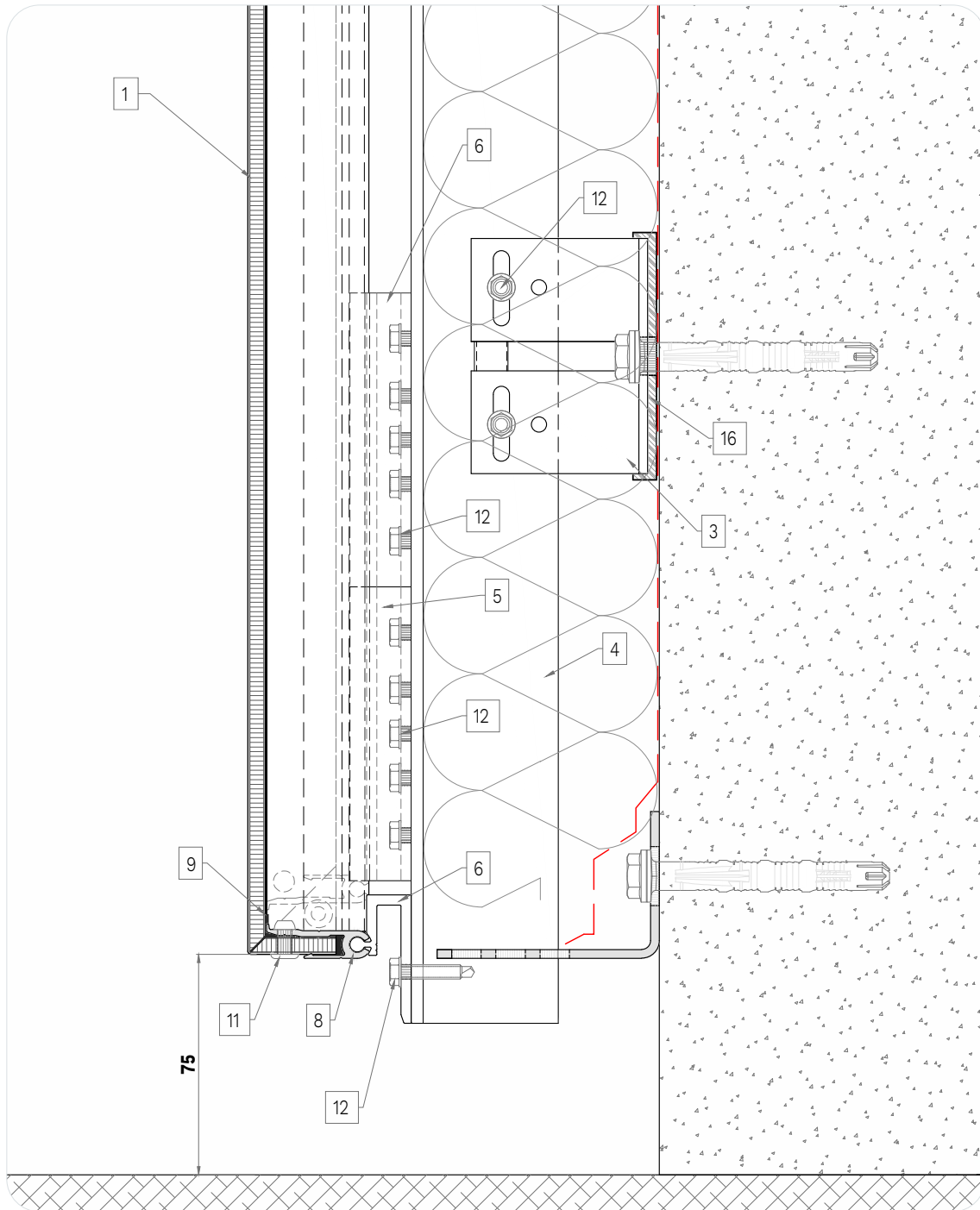

**05b. Facade starting II**

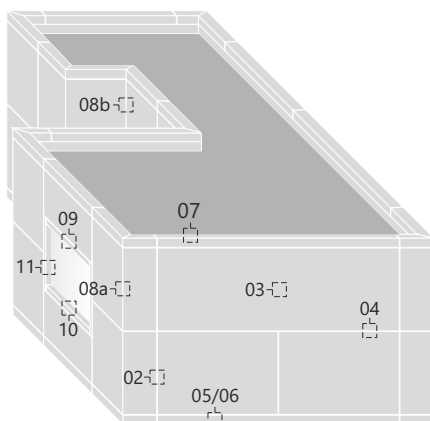

- 1. larcore® A2 6 mm panel
- 2. LT-1A wind-weight bracket
- 3. LT-1B wind bracket
- 4. LT-2 vertical profile
- 5. LT-31M tall mobile clip
- 6. LT-31F tall fixed clip
- 7. LT-32M short mobile clip
- 8. LT-4 perimetral profile
- 9. DOWSIL™ 7092 Adhesive and Sealant silicone
- 10. Ø4.8x8mm Alu/A2 waterproofing rivet
- 11. Ø4.8x14mm Alu/A2 standard rivet
- 12. EJOT JT4-ZT4 Ø4.8x25mm A2 TORX® T25
- 13. LC-RH intermediate stiffener
- 14. SikaTack Panel 50 adhesive
- 15. INDEX Ø4.2x32mm A2/50 flat head screw
- 16. LT-0A/B thermal break
- 17. 2-3mm aluminum plate

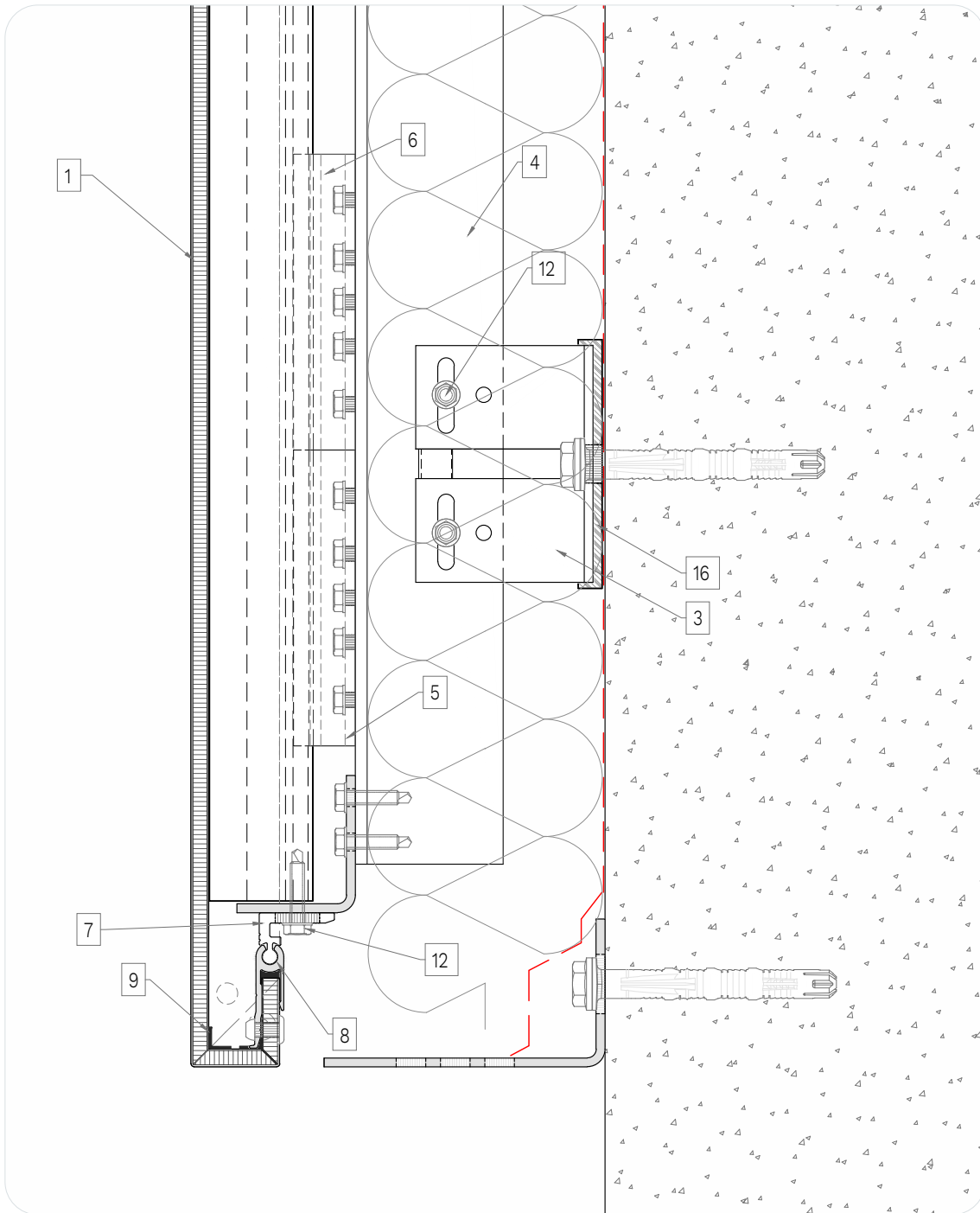

**06a. High façade starting I**

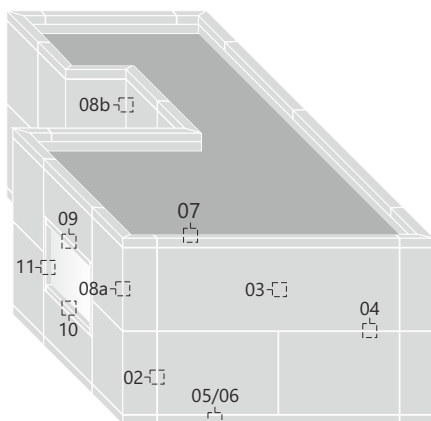

- 1. Iarc core® A2 6 mm panel
- 2. LT-1A wind-weight bracket
- 3. LT-1B wind bracket
- 4. LT-2 vertical profile
- 5. LT-31M tall mobile clip
- 6. LT-31F tall fixed clip
- 7. LT-32M short mobile clip
- 8. LT-4 perimetral profile
- 9. DOWSIL™ 7092 Adhesive and Sealant silicone
- 10. Ø4.8x8mm Alu/A2 waterproofing rivet
- 11. Ø4.8x14mm Alu/A2 standard rivet
- 12. EJOT JT4-ZT4 Ø4.8x25mm A2 TORX® T25
- 13. LC-RH intermediate stiffener
- 14. SikaTack Panel 50 adhesive
- 15. INDEX Ø4.2x32mm A2/50 flat head screw
- 16. LT-0A/B thermal break
- 17. 2-3mm aluminum plate

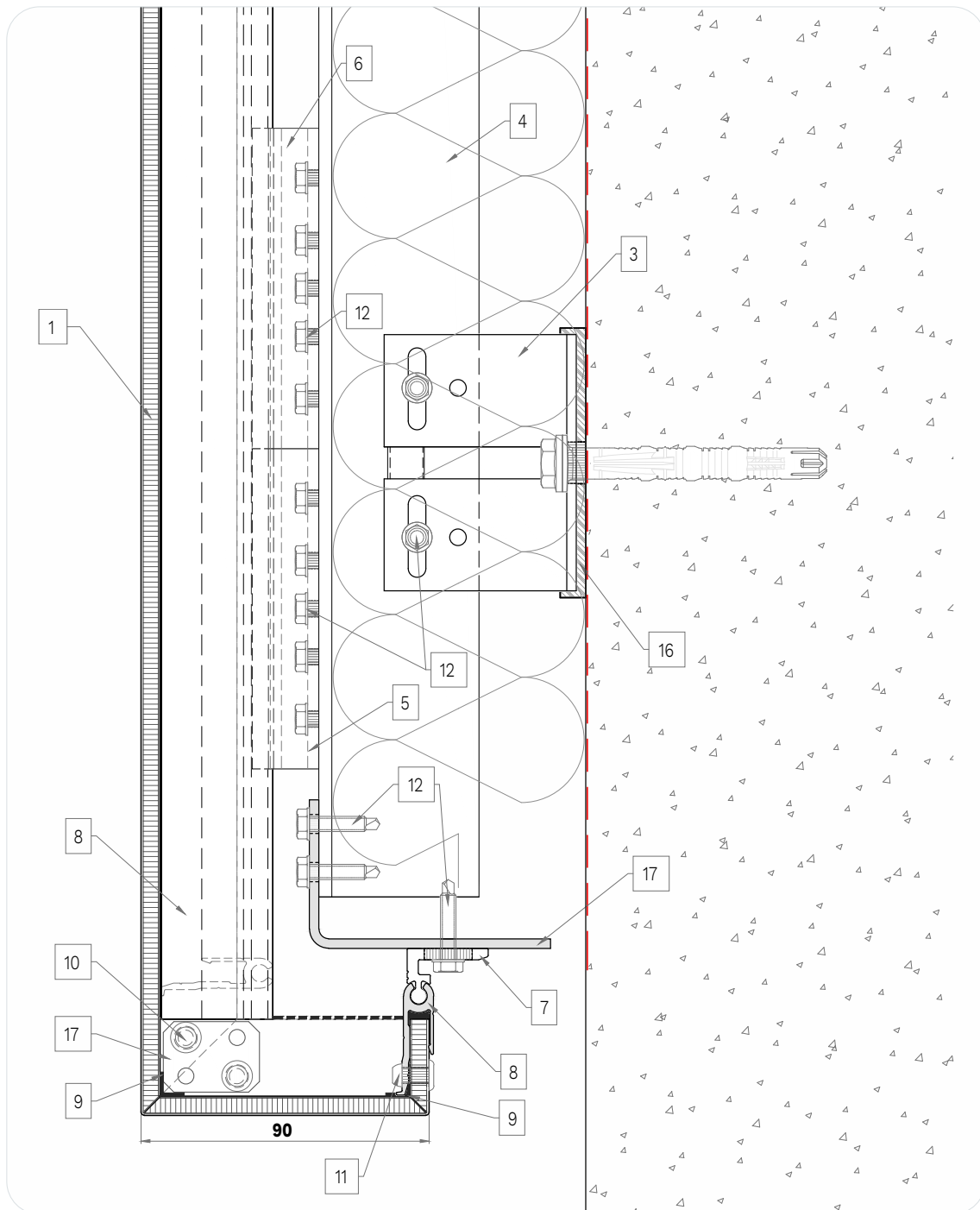

**06b. High façade starting II**

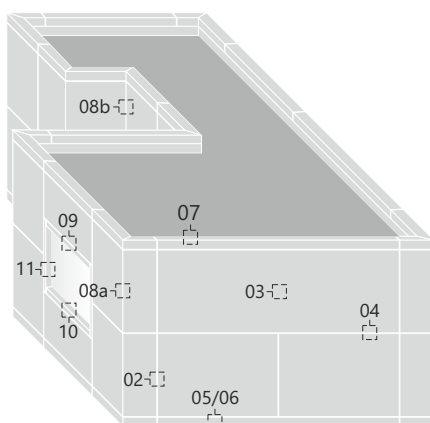

- 1. larcore® A2 6 mm panel
- 2. LT-1A wind-weight bracket
- 3. LT-1B wind bracket
- 4. LT-2 vertical profile
- 5. LT-31M tall mobile clip
- 6. LT-31F tall fixed clip
- 7. LT-32M short mobile clip
- 8. LT-4 perimeteral profile
- 9. DOWSIL™ 7092 Adhesive and Sealant silicone
- 10. Ø4.8x8mm Alu/A2 waterproofing rivet
- 11. Ø4.8x14mm Alu/A2 standard rivet
- 12. EJOT JT4-ZT4 Ø4.8x25mm A2 TORX® T25
- 13. LC-RH intermediate stiffener
- 14. SikaTack Panel 50 adhesive
- 15. INDEX Ø4.2x32mm A2/50 flat head screw
- 16. LT-0A/B thermal break
- 17. 2-3mm aluminum plate

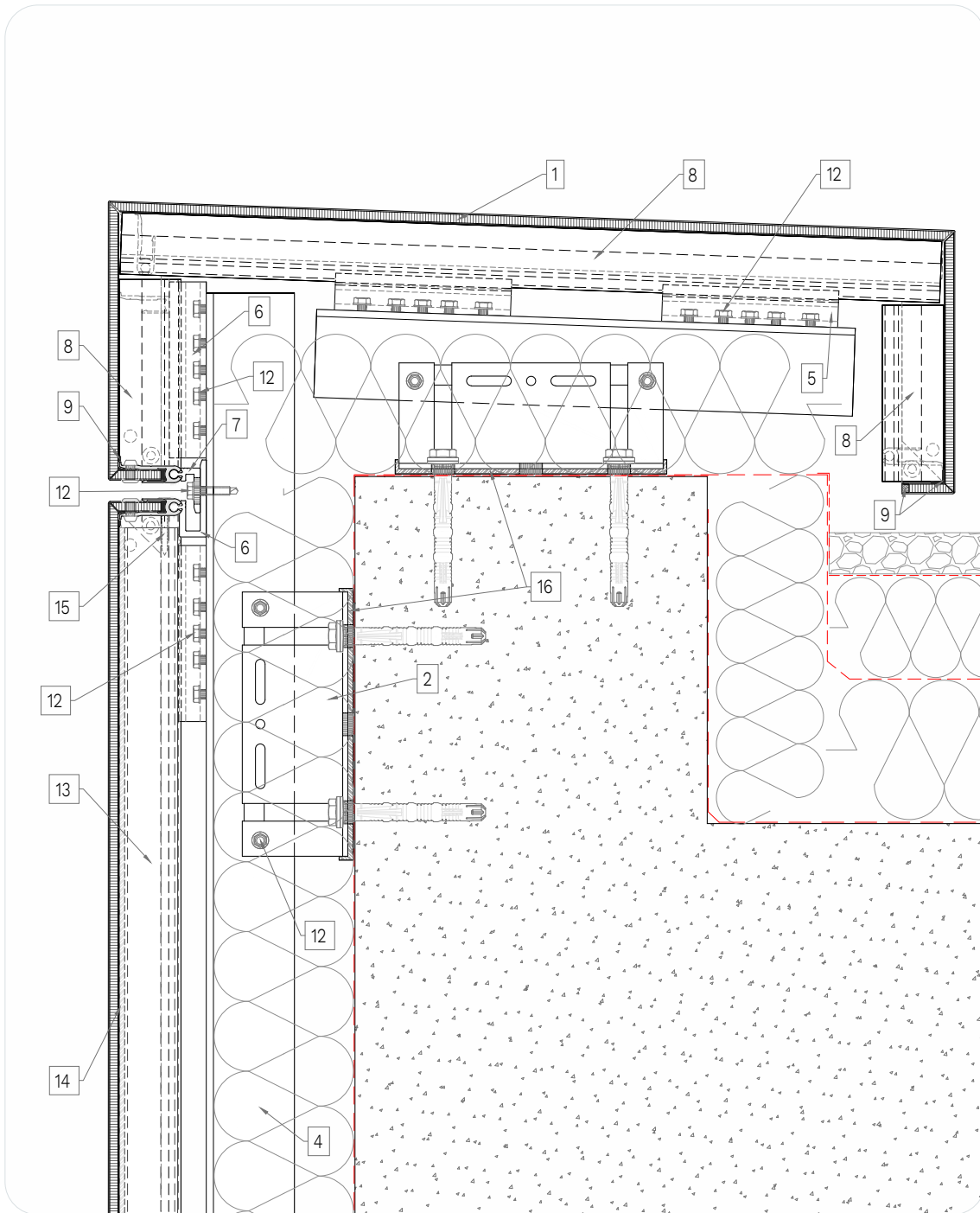

**07. Parapet detail**

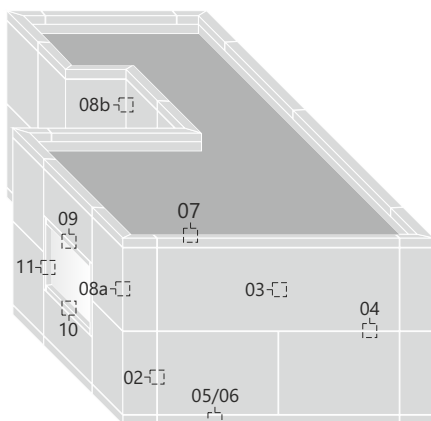

- 1. Iarc core® A2 6 mm panel
- 2. LT-1A wind-weight bracket
- 3. LT-1B wind bracket
- 4. LT-2 vertical profile
- 5. LT-31M tall mobile clip
- 6. LT-31F tall fixed clip
- 7. LT-32M short mobile clip
- 8. LT-4 perimetral profile
- 9. DOWSIL™ 7092 Adhesive and Sealant silicone
- 10. Ø4.8x8mm Alu/A2 waterproofing rivet
- 11. Ø4.8x14mm Alu/A2 standard rivet
- 12. EJOT JT4-ZT4 Ø4.8x25mm A2 TORX® T25
- 13. LC-RH intermediate stiffener
- 14. SikaTack Panel 50 adhesive
- 15. INDEX Ø4.2x32mm A2/50 flat head screw
- 16. LT-0A/B thermal break
- 17. 2-3mm aluminum plate

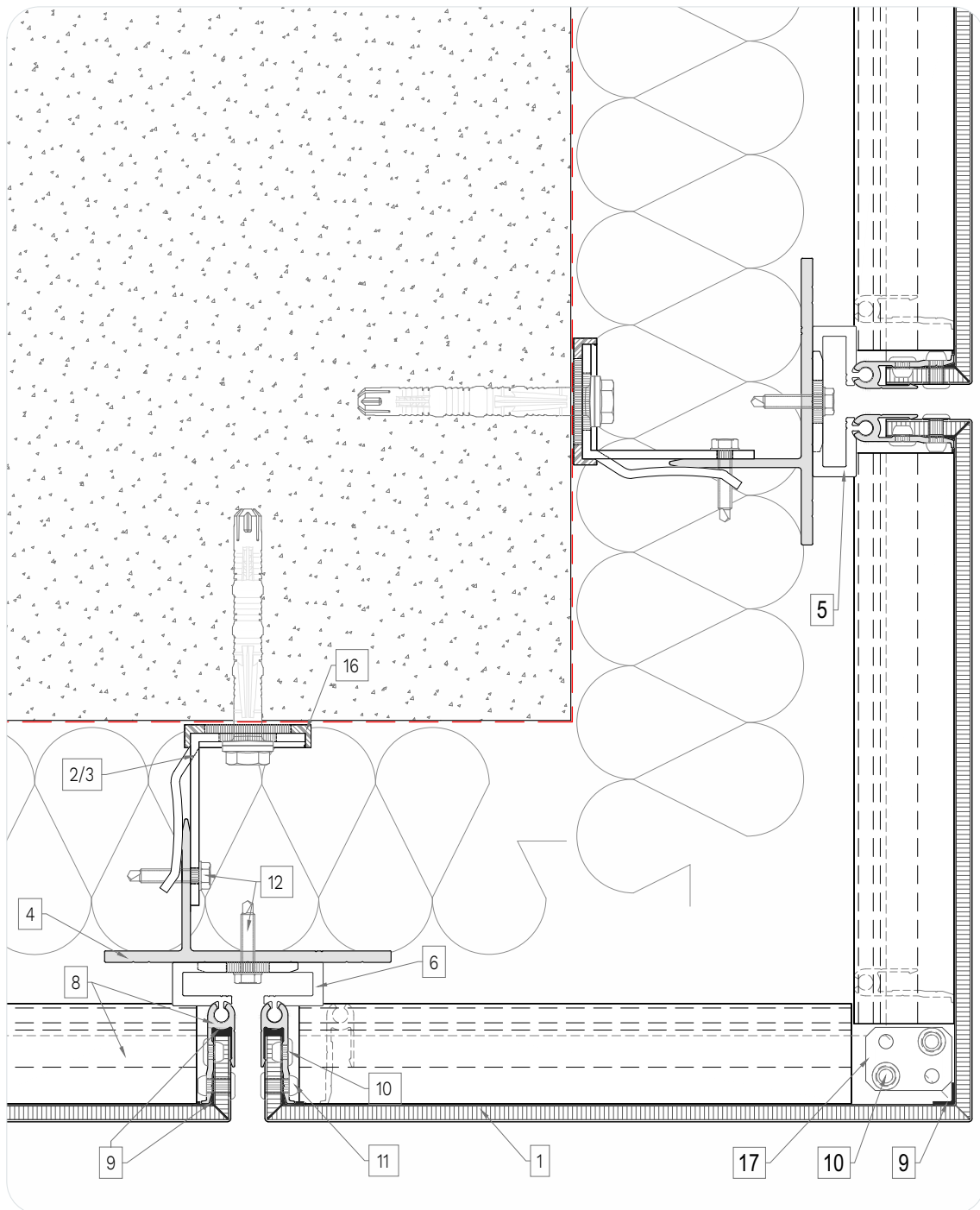

**08a. External corner**

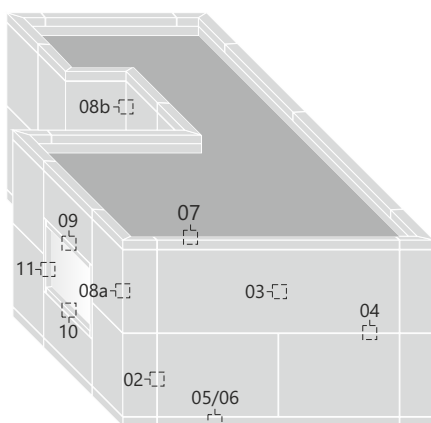

1. larcore® A2 6 mm panel
2. LT-1A wind-weight bracket
3. LT-1B wind bracket
4. LT-2 vertical profile
5. LT-31M tall mobile clip
6. LT-31F tall fixed clip
7. LT-32M short mobile clip
8. LT-4 perimetral profile
9. DOWSIL™ 7092 Adhesive and Sealant silicone
10. Ø4.8x8mm Alu/A2 waterproofing rivet
11. Ø4.8x14mm Alu/A2 standard rivet
12. EJOT JT4-ZT4 Ø4.8x25mm A2 TORX® T25
13. LC-RH intermediate stiffener
14. SikaTack Panel 50 adhesive
15. INDEX Ø4.2x32mm A2/50 flat head screw
16. LT-0A/B thermal break
17. 2-3mm aluminum plate

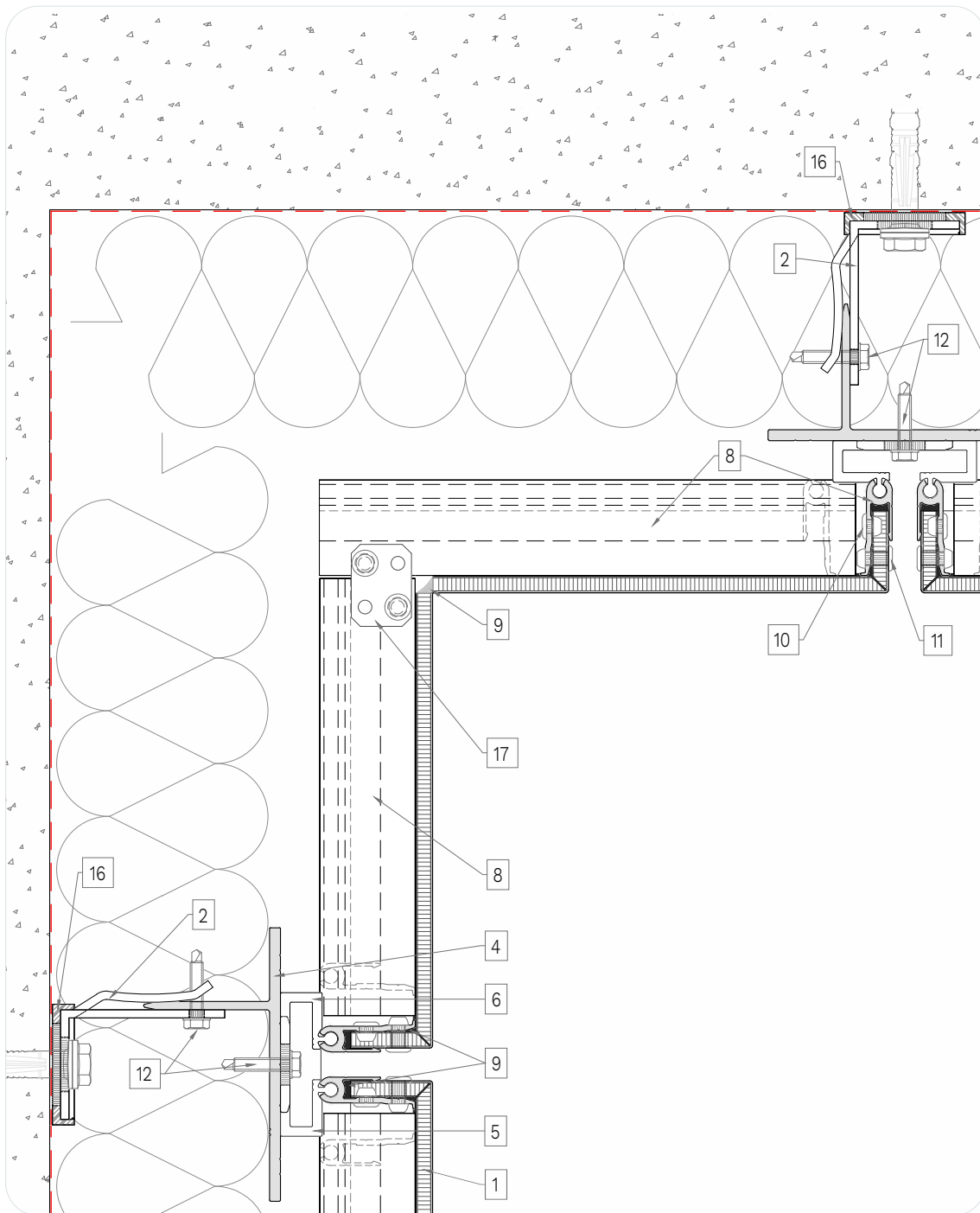

**08b. Internal corner**

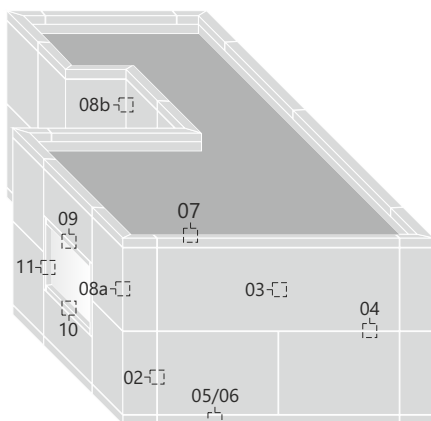

1. Iarcore® A2 6 mm panel
2. LT-1A wind-weight bracket
3. LT-1B wind bracket
4. LT-2 vertical profile
5. LT-31M tall mobile clip
6. LT-31F tall fixed clip
7. LT-32M short mobile clip
8. LT-4 perimetral profile
9. DOWSIL™ 7092 Adhesive and Sealant silicone
10. Ø4.8x8mm Alu/A2 waterproofing rivet
11. Ø4.8x14mm Alu/A2 standard rivet
12. EJOT JT4-ZT4 Ø4.8x25mm A2 TORX® T25
13. LC-RH intermediate stiffener
14. SikaTack Panel 50 adhesive
15. INDEX Ø4.2x32mm A2/50 flat head screw
16. LT-0A/B thermal break
17. 2-3mm aluminum plate



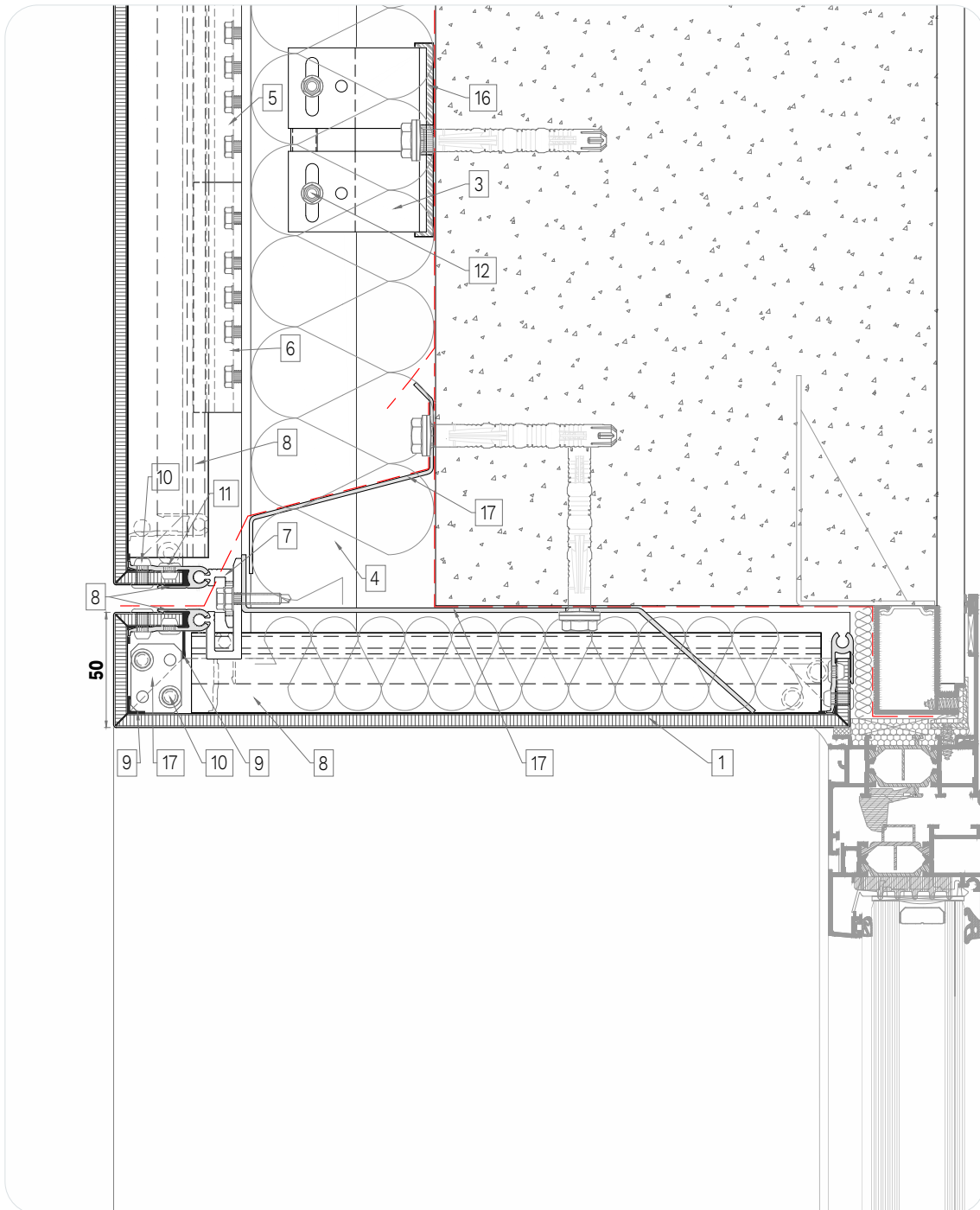

### 09. Window head detail

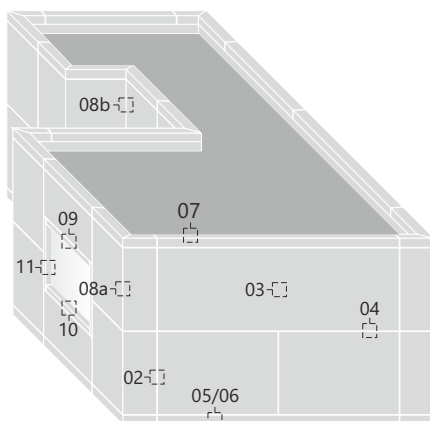

- 1. larcore® A2 6 mm panel
- 2. LT-1A wind-weight bracket
- 3. LT-1B wind bracket
- 4. LT-2 vertical profile
- 5. LT-31M tall mobile clip
- 6. LT-31F tall fixed clip
- 7. LT-32M short mobile clip
- 8. LT-4 perimetral profile
- 9. DOWSIL™ 7092 Adhesive and Sealant silicone
- 10. Ø4.8x8mm Alu/A2 waterproofing rivet
- 11. Ø4.8x14mm Alu/A2 standard rivet
- 12. EJOT JT4-ZT4 Ø4.8x25mm A2 TORX® T25
- 13. LC-RH intermediate stiffener
- 14. SikaTack Panel 50 adhesive
- 15. INDEX Ø4.2x32mm A2/50 flat head screw
- 16. LT-0A/B thermal break
- 17. 2-3mm aluminum plate

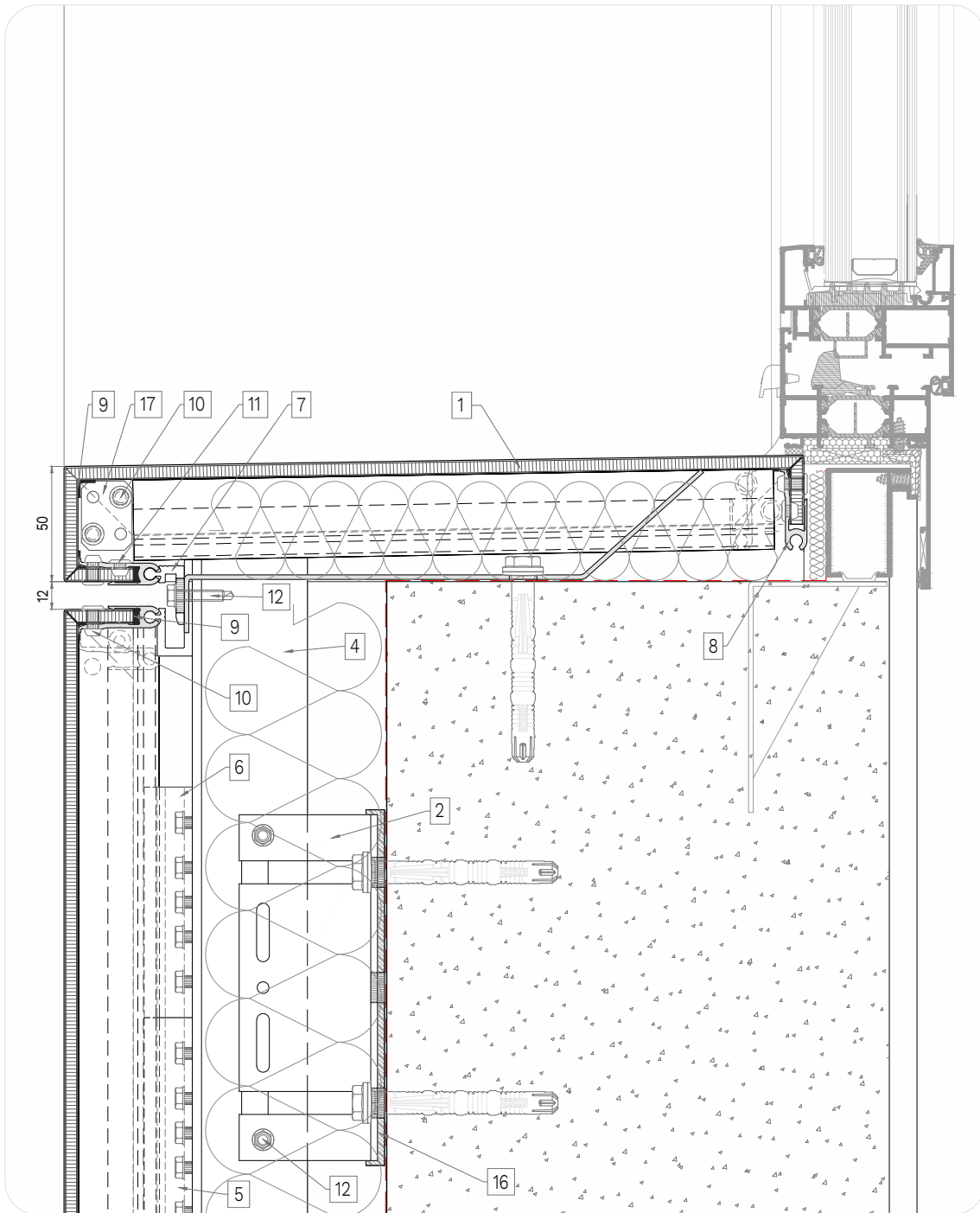

**10. Window sill detail**

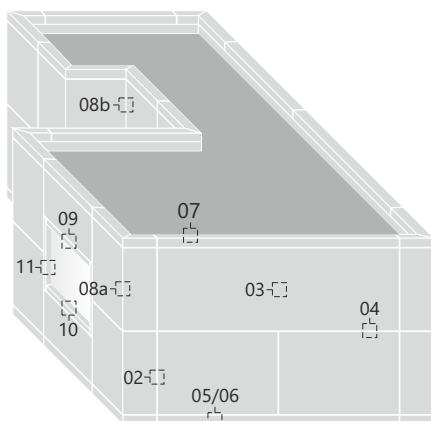

- 1.** Iarcoring® A2 6 mm panel
- 2.** LT-1A wind-weight bracket
- 3.** LT-1B wind bracket
- 4.** LT-2 vertical profile
- 5.** LT-31M tall mobile clip
- 6.** LT-31F tall fixed clip
- 7.** LT-32M short mobile clip
- 8.** LT-4 perimetral profile
- 9.** DOWSIL™ 7092 Adhesive and Sealant silicone
- 10.** Ø4.8x8mm Alu/A2 waterproofing rivet
- 11.** Ø4.8x14mm Alu/A2 standard rivet
- 12.** EJOT JT4-ZT4 Ø4.8x25mm A2 TORX® T25
- 13.** LC-RH intermediate stiffener
- 14.** SikaTack Panel 50 adhesive
- 15.** INDEX Ø4.2x32mm A2/50 flat head screw
- 16.** LT-0A/B thermal break
- 17.** 2-3mm aluminum plate

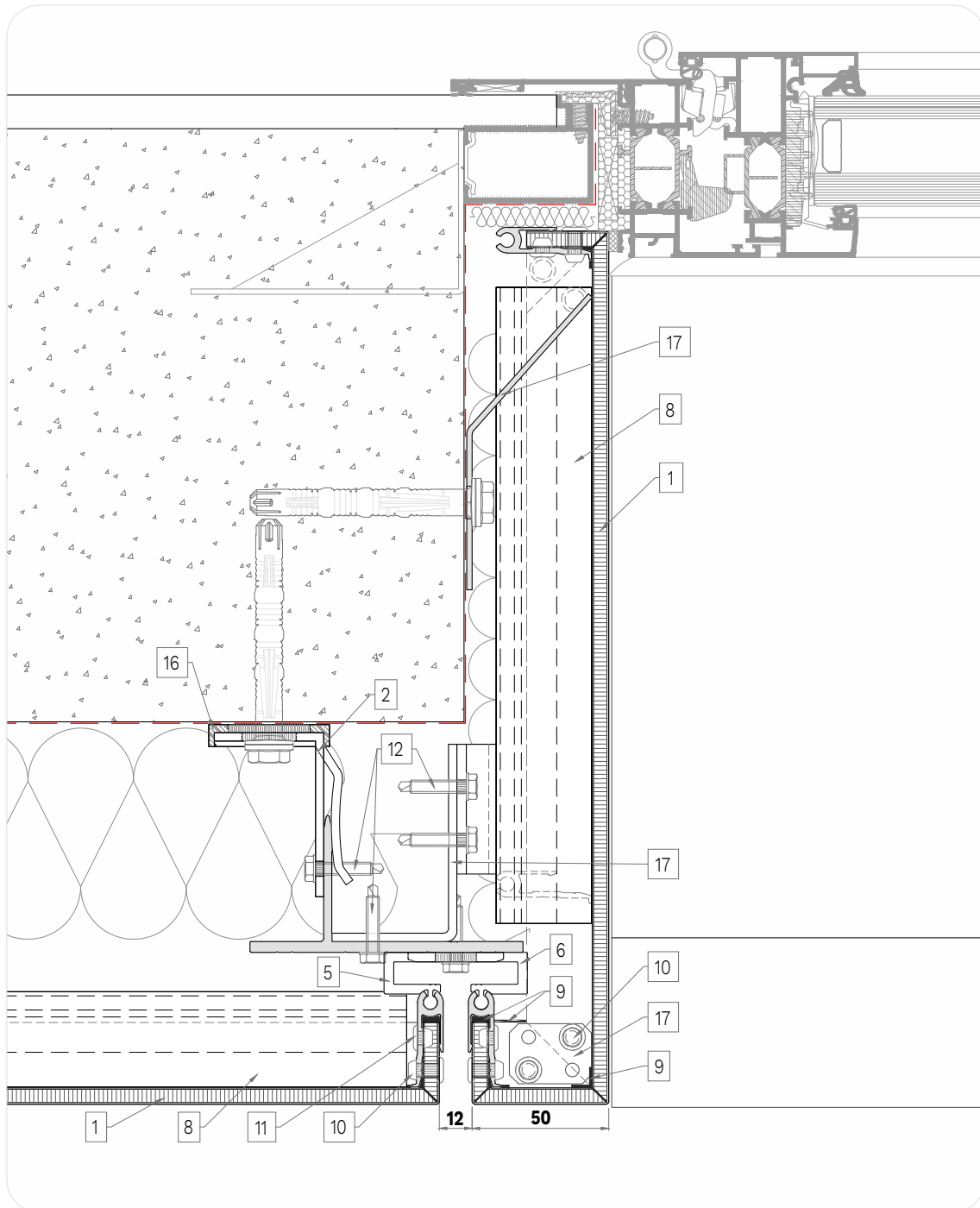

**11. Window jamb detail**

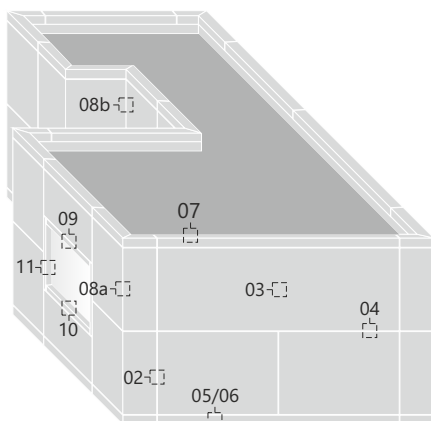

- 1.** larcore® A2 6 mm panel
- 2.** LT-1A wind-weight bracket
- 3.** LT-1B wind bracket
- 4.** LT-2 vertical profile
- 5.** LT-31M tall mobile clip
- 6.** LT-31F tall fixed clip
- 7.** LT-32M short mobile clip
- 8.** LT-4 perimetral profile
- 9.** DOWSIL™ 7092 Adhesive and Sealant silicone
- 10.** Ø4.8x8mm Alu/A2 waterproofing rivet
- 11.** Ø4.8x14mm Alu/A2 standard rivet
- 12.** EJOT JT4-ZT4 Ø4.8x25mm A2 TORX® T25
- 13.** LC-RH intermediate stiffener
- 14.** SikaTack Panel 50 adhesive
- 15.** INDEX Ø4.2x32mm A2/50 flat head screw
- 16.** LT-0A/B thermal break
- 17.** 2-3mm aluminum plate



## 17. Iarc core® A2 14 mm panels. Hidetch® PRO installation systems.



### a) Machining of the 14 mm Iarc core® A2 panel for installation with the Hidetch® PRO system.

**Hidetch® PRO** installation system allows installing **Iarc core® A2** panels with a total thickness of 14 mm. These panels must be edged around the perimeter to ensure their sealing and they will be hung to the vertical profiles of the system by means of aluminum hangers that are mechanically fixed by rivets on the internal face of the panel.

#### HOW TO CARRY OUT THE PANEL EDGING:

- Cut the honeycomb panel to the accurate dimensions (see sketch above).
- Machine the panel according to chosen option.
- The internal aluminium sheet will be machined to advantage the bending and folding of every edge.
- The panel will be machined to allow the double edging and its subsequent shaped.
- The standard solution for Architectural ventilated facades will be double edging WITH 10° slope.
- Double edged will have at least two rivets on each edge, and the distance between them shall not exceed 300mm.
- A rivet is always placed on each side of the corners (approximately 30mm).
- **Alucoil®** recommendation is to use a standard rivet UNE EN ISO 15981 Ø4x6mm (protruding head, diameter dk=8mm with aluminium body diameter d=4 mm and L=6mm length and aluminium mandrel as well)
- **Alucoil®** would machine the panel if needed, including every hole, and would carry out the panel edging, but the client must rivet the edging.

COMMENT: UNE EN ISO 15981 Ø4x6mm rivet DOES NOT FIT 6mm panel, in that case we would have to use a rivet with aluminium or stainless steel mandrel and body length L=4mm. Ex.: BRALO remache estándar AIA/A2 Ø2,4x4mm.

#### T-bend > 2

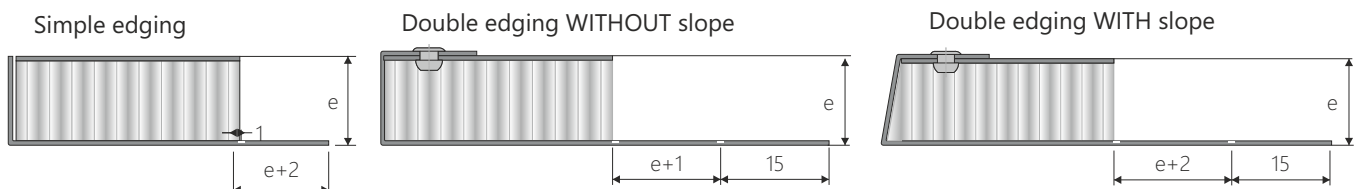
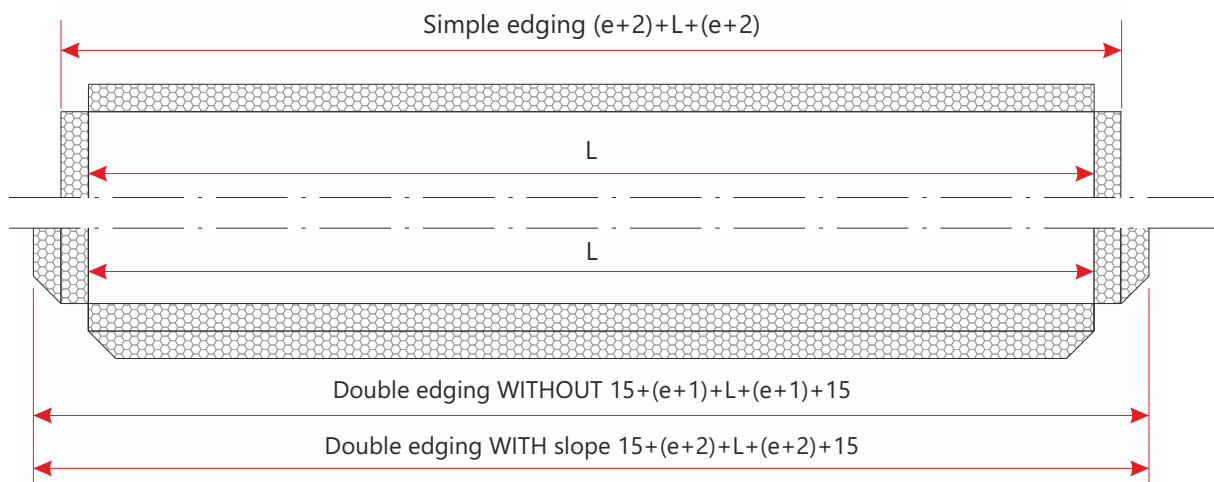

**Alucoil®** offers 3 edging possibilities for its composite panel with Honeycomb core:

- 1) Double edging WITHOUT slope (15mm thickness maximum).
- 2) Double edging WITH 10° slope (15mm thickness maximum). Mandatory for ventilated facades.
- 3) Simple edging.

When making optimization of the panels, it must be taken into account extra material needed to make the edging (single or double).

*Double edging With and WITHOUT slope example: larcore® A2 10 mm thickness:*

*Panel tolerance:*

*a) Length: 0 / +2mm*

*b) Width: 0 / +2mm*

*Installed panel: 3000x1500mm*

*Needed panel double edging WITHOUT slope: 3052x1552mm*

*Needed panel double edging WITH 10° slope: 3054x1554mm*

### **b) Speed and advance conditions for edging machine used in Alucoil®.**

#### **EDGING CLOSING.**

The closing of the edges of **larcore® A2** panels is done in a special roll-forming machine for volumetric (solid) bodies which closes the edge of the panel perfectly for the installation. Due to the characteristics of the edge closing machine, only the edges of pieces which are not in conflict with the rollers can be closed.

*Edging machine of 10 rollers and Ø50 mm.*

*a) Advance: 10 m/min.*

*b) Edging length: 2,5 m.*

*c) Edging from 1 mm until 30 mm.*

*Routing for edging of the panel will be made with a tool D.22 mm. Hard metal.*

*a) Maximum:  $V_{RPM}: 10000$  / Advance: 4m/min.*

*b) Standard:  $V_{RPM}: 10000$  / Advance: 4m/min.*

*c) Minimum:  $V_{RPM}: 5000$  / Advance: 2m/min.*

- Cutting tolerances: size requested +/- 1 mm.
- Tolerances in the edging routing depth: -0.1 mm.
- Edging Larcore Tolerances: 0, +1,5 mm per edging.

Machining specifications CNC (data base on tools and machinery used in **Alucoil®** for other conditions see the technical characteristics of the tool supplier).

A: 5mm

B: (6-8-10-14-15-20)mm

C: 0,5 mm / 0,7 mm / 1 mm

D: 0,7 mm / 1 mm

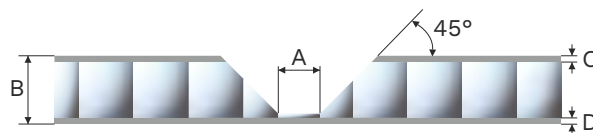

#### **IMPORTANT:**

All processing jobs must be done using protection gloves and security goggles to avoid wounds or injuries by shavings. All processing jobs of **larcore® A2** must be done with the protective plastic film to avoid damages and at temperatures above 10°C on coated surface. The plastic film must remain until all processing jobs have been finished.



**c) Hidetech® PRO installation system development by Alucoil®.**

**Iarcoring® A2 14 mm panels.**  
**Hidetech® PRO installation system.**

It would be customer responsibility to verify that any product supplied complies with applicable regulations related to product installation, and, in particular, with any regulations regarding fire resistance and fire reaction.

The information and measures contained in this document are for conceptual and theoretical use only. **Alucoil®** shall have no responsibility for these products usage and installation.

The inappropriate use and total or partial reproduction is forbidden, except if expressly authorized by **Alucoil® S.A.U.**

Panel design, transformation and transformation and installation are the sole responsibility of the purchaser.

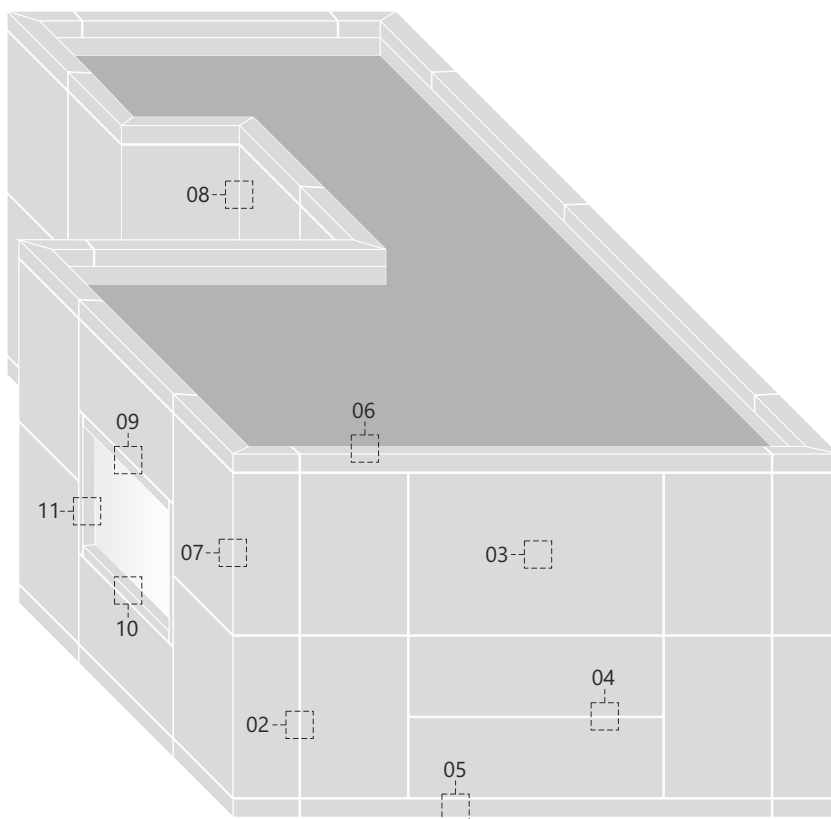

- 01.** Outside elevation
- 02.** Vertical joint
- 03.** Intermediate clip
- 04.** Horizontal joint
- 05.** Façade starting I
- 06.** Parapet detail
- 07.** External corner
- 08.** Internal corner
- 09.** Window head detail
- 10.** Window sill detail
- 11.** Window jamb detail

**Hidetech® PRO installation system for larcore® A2 14 mm panels.**

**System accessories**



**LT-0A+LT-1A** wind weight bracket



**LT-0B+LT-1B** wind bracket



**PRO-6R** clip (regulation)



**PRO-6** clip

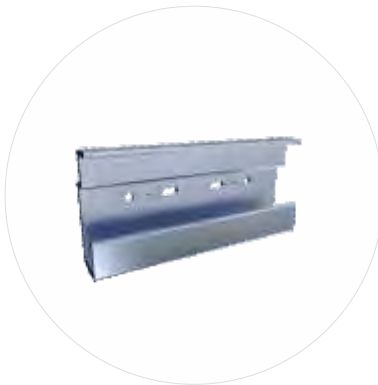

**PRO-5** short hanger

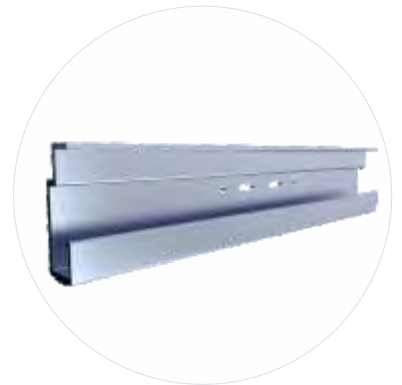

**PRO-5** long hanger



**LT-1A** bracket + **LT-2** y **PRO-5** profile



**larcore® A2 14 mm** panel with double edged. Hanger piece

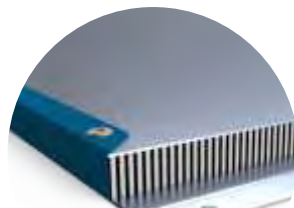
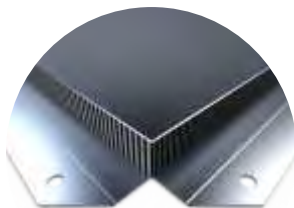



**Outside elevation of the Hidetech® PRO installation system for Iarcoring® A2 14 mm**





**Hidetch® PRO** installation system “**larcore® A2 14 mm** panels”.

01. Outside elevation.

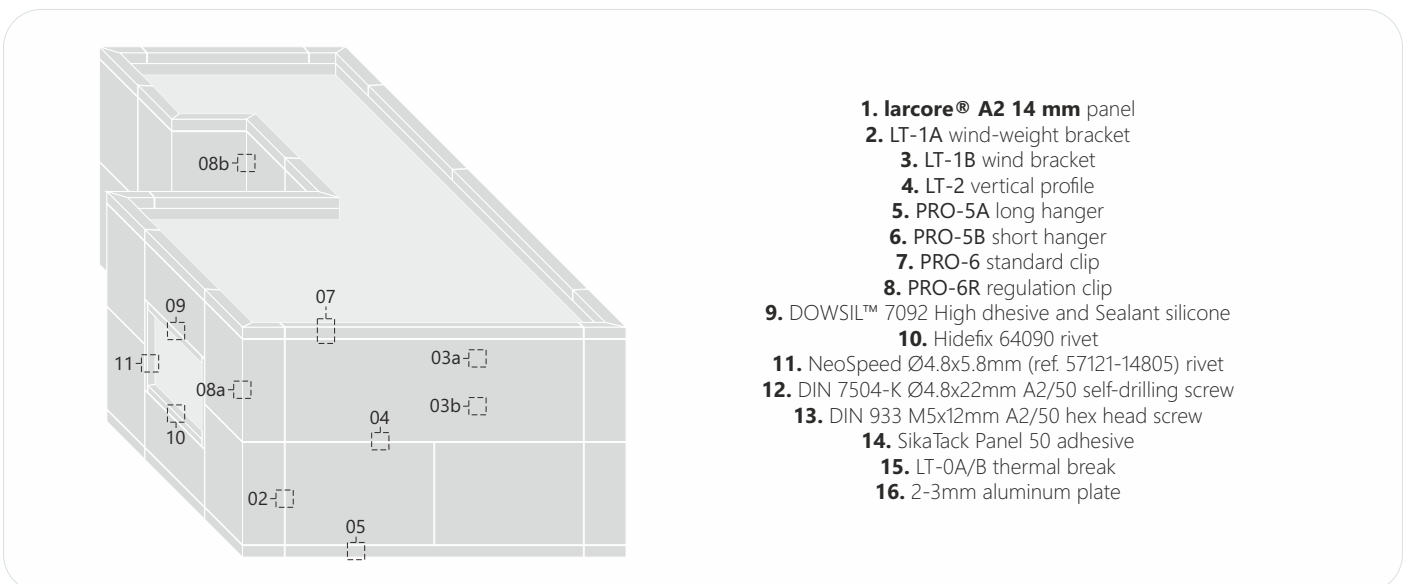
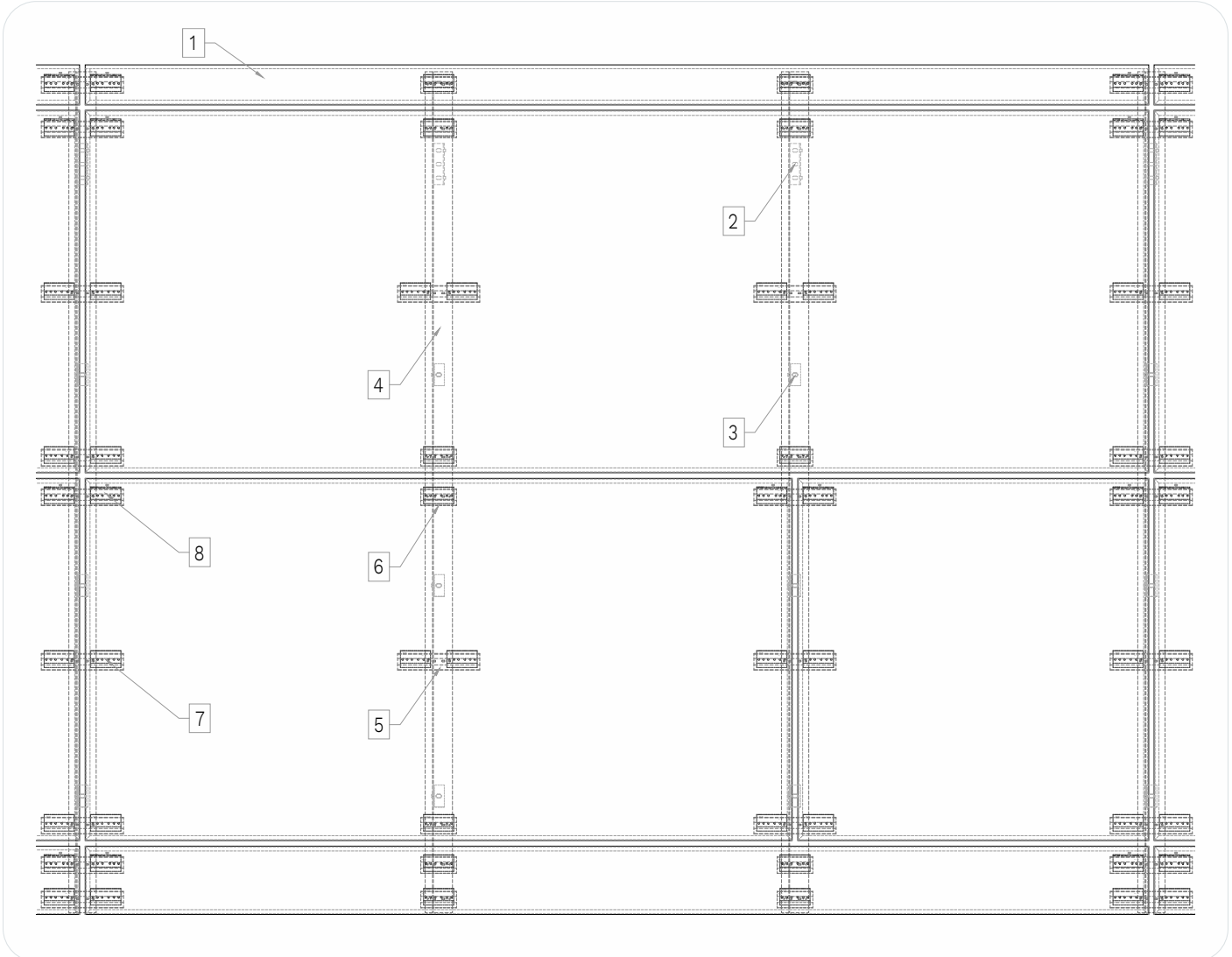

- 1. **larcore® A2 14 mm** panel
- 2. LT-1A wind-weight bracket
- 3. LT-1B wind bracket
- 4. LT-2 vertical profile
- 5. PRO-5A long hanger
- 6. PRO-5B short hanger
- 7. PRO-6 standard clip
- 8. PRO-6R regulation clip
- 9. DOWSIL™ 7092 High adhesive and Sealant silicone
- 10. Hidefix 64090 rivet
- 11. NeoSpeed Ø4.8x5.8mm (ref. 57121-14805) rivet
- 12. DIN 7504-K Ø4.8x22mm A2/50 self-drilling screw
- 13. DIN 933 M5x12mm A2/50 hex head screw
- 14. SikaTack Panel 50 adhesive
- 15. LT-0A/B thermal break
- 16. 2-3mm aluminum plate

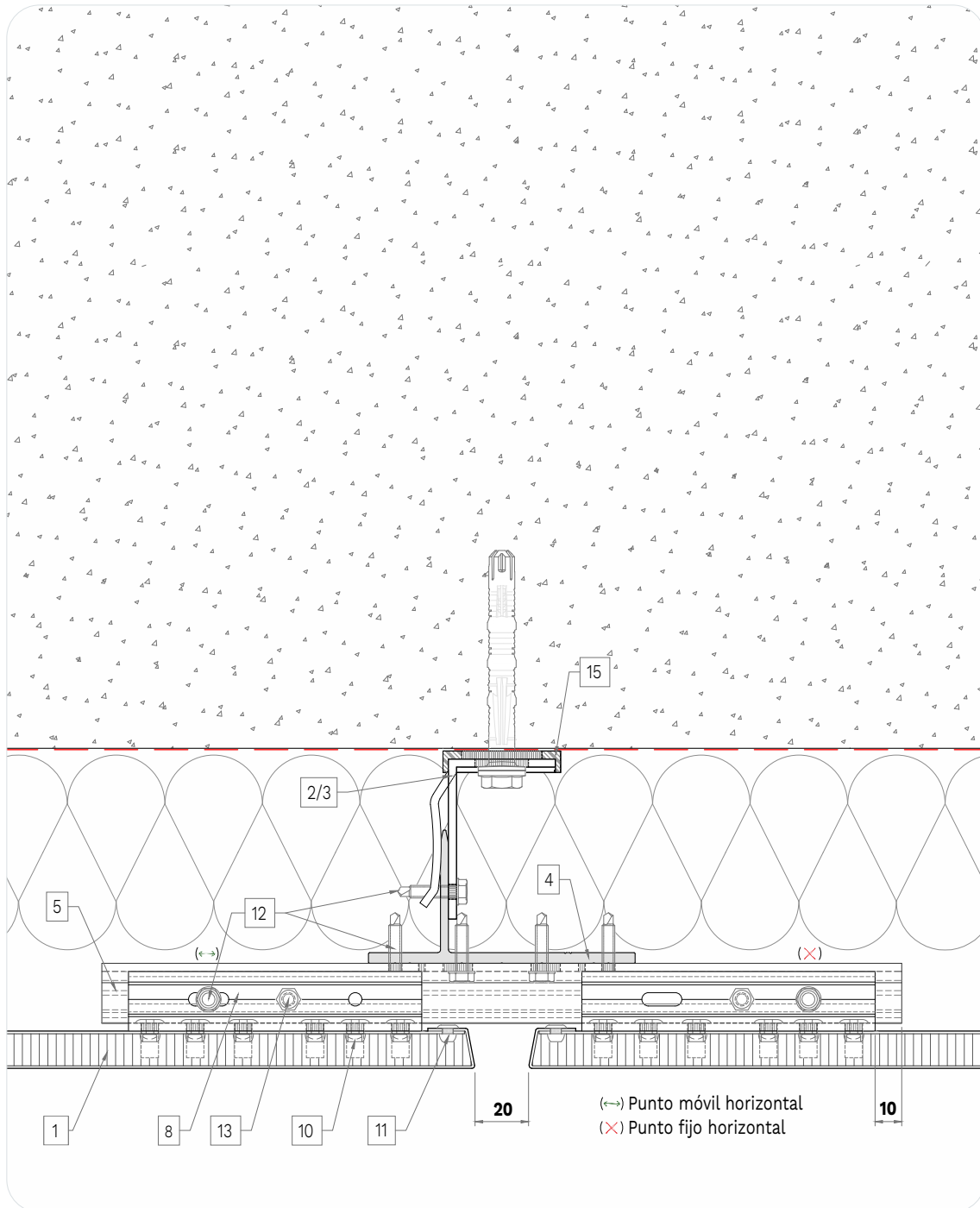

## 02. Vertical joint

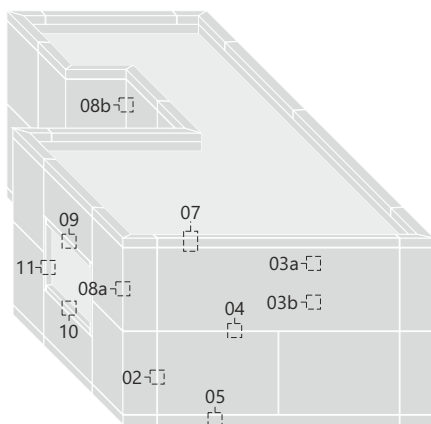

1. Iarcoring® A2 14 mm panel
2. LT-1A wind-weight bracket
3. LT-1B wind bracket
4. LT-2 vertical profile
5. PRO-5A long hanger
6. PRO-5B short hanger
7. PRO-6 standard clip
8. PRO-6R regulation clip
9. DOWSIL™ 7092 High adhesive and Sealant silicone
10. Hidefix 64090 rivet
11. NeoSpeed Ø4.8x5.8mm (ref. 57121-14805) rivet
12. DIN 7504-K Ø4.8x22mm A2/50 self-drilling screw
13. DIN 933 M5x12mm A2/50 hex head screw
14. SikaTack Panel 50 adhesive
15. LT-0A/B thermal break
16. 2-3mm aluminum plate

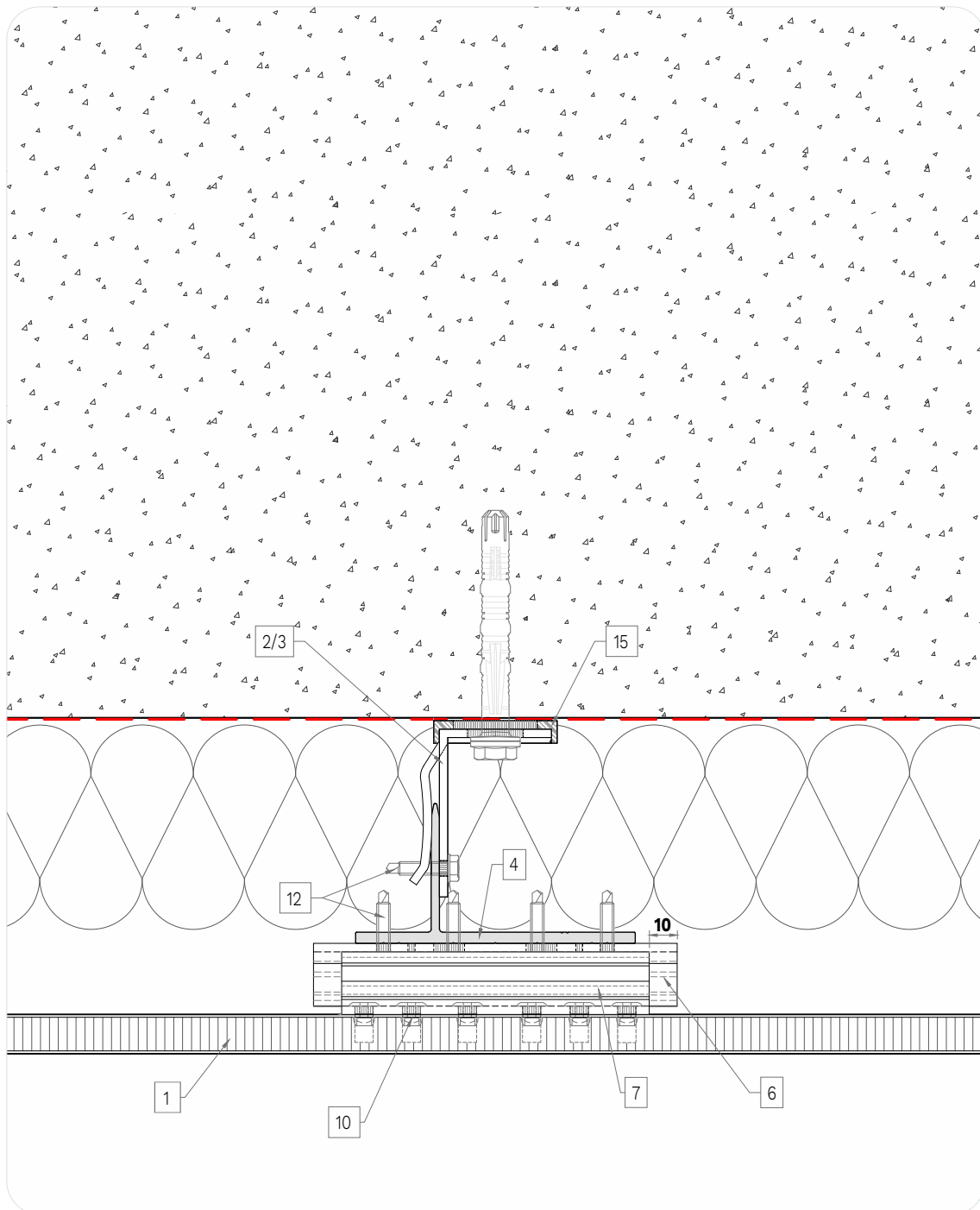

### 03a. Intermediate short hanger

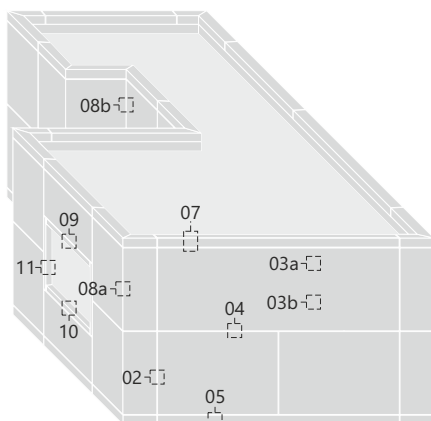

1. larcore® A2 14 mm panel
2. LT-1A wind-weight bracket
3. LT-1B wind bracket
4. LT-2 vertical profile
5. PRO-5A long hanger
6. PRO-5B short hanger
7. PRO-6 standard clip
8. PRO-6R regulation clip
9. DOWSIL™ 7092 High adhesive and Sealant silicone
10. Hidefix 64090 rivet
11. NeoSpeed Ø4.8x5.8mm (ref. 57121-14805) rivet
12. DIN 7504-K Ø4.8x22mm A2/50 self-drilling screw
13. DIN 933 M5x12mm A2/50 hex head screw
14. SikaTack Panel 50 adhesive
15. LT-0A/B thermal break
16. 2-3mm aluminum plate

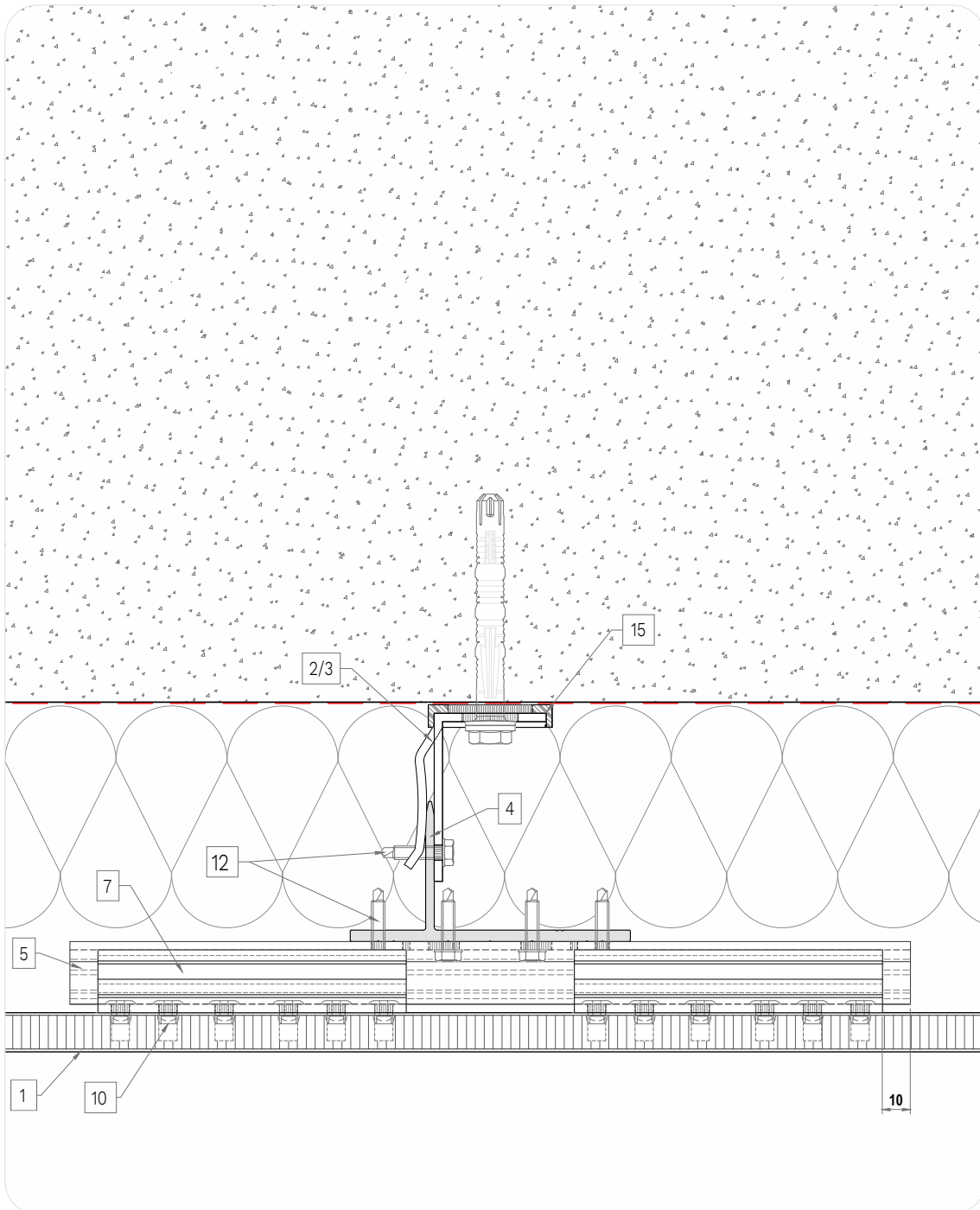

### 03b. Intermediate long hanger

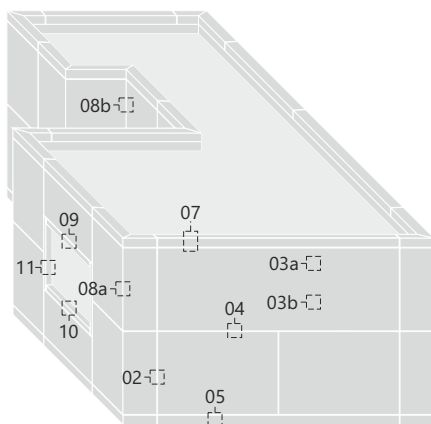

- 1. Iarcoring® A2 14 mm panel
- 2. LT-1A wind-weight bracket
- 3. LT-1B wind bracket
- 4. LT-2 vertical profile
- 5. PRO-5A long hanger
- 6. PRO-5B short hanger
- 7. PRO-6 standard clip
- 8. PRO-6R regulation clip
- 9. DOWSIL™ 7092 High adhesive and Sealant silicone
- 10. Hidefix 64090 rivet
- 11. NeoSpeed Ø4.8x5.8mm (ref. 57121-14805) rivet
- 12. DIN 7504-K Ø4.8x22mm A2/50 self-drilling screw
- 13. DIN 933 M5x12mm A2/50 hex head screw
- 14. SikaTack Panel 50 adhesive
- 15. LT-0A/B thermal break
- 16. 2-3mm aluminum plate

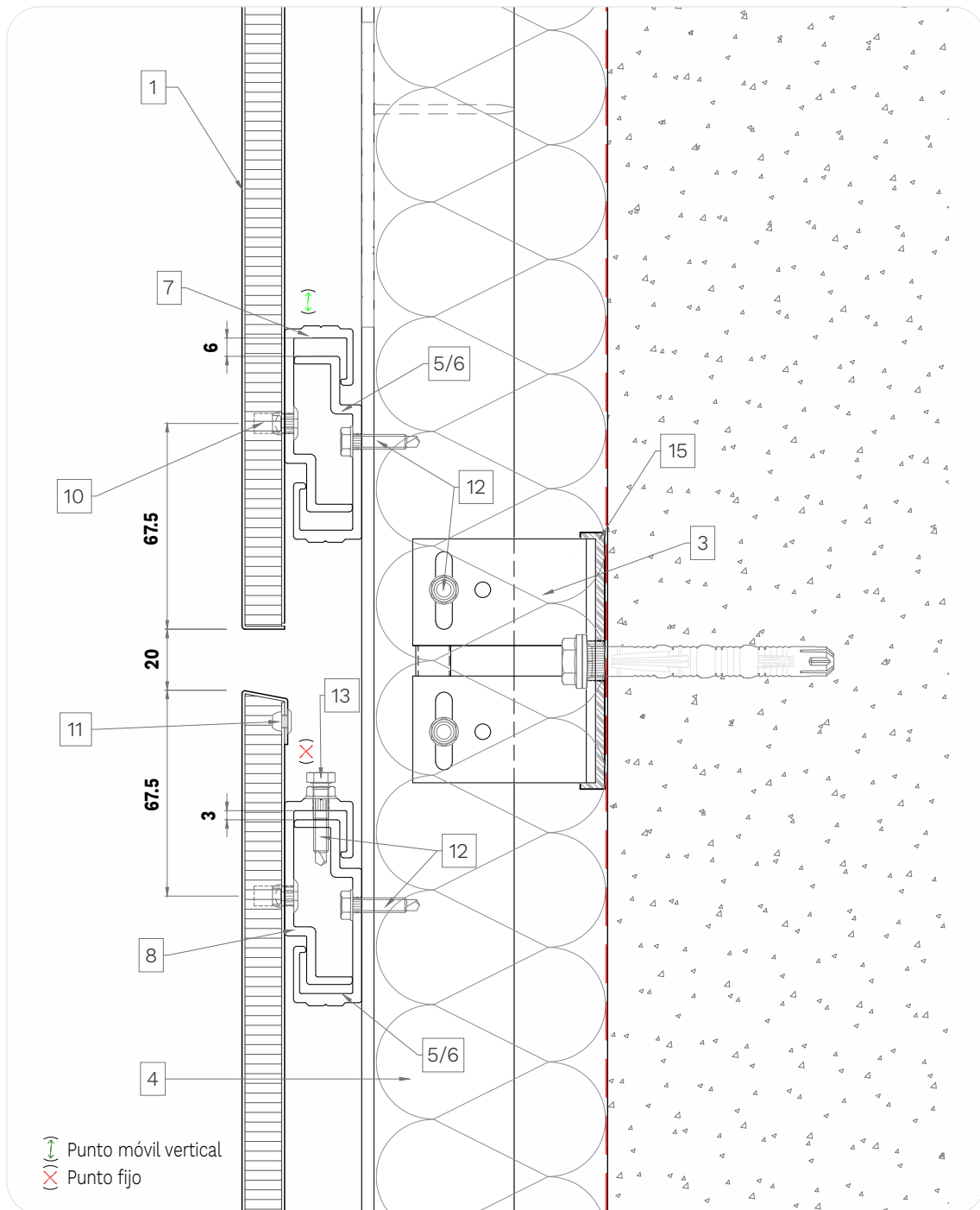

#### 04. Horizontal joint

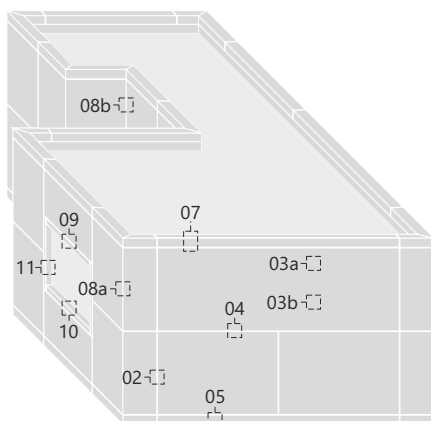

1. larcore® A2 14 mm panel
2. LT-1A wind-weight bracket
3. LT-1B wind bracket
4. LT-2 vertical profile
5. PRO-5A long hanger
6. PRO-5B short hanger
7. PRO-6 standard clip
8. PRO-6R regulation clip
9. DOWSIL™ 7092 High dhesive and Sealant silicone
10. Hidefix 64090 rivet
11. NeoSpeed Ø4.8x5.8mm (ref. 57121-14805) rivet
12. DIN 7504-K Ø4.8x22mm A2/50 self-drilling screw
13. DIN 933 M5x12mm A2/50 hex head screw
14. SikaTack Panel 50 adhesive
15. LT-0A/B thermal break
16. 2-3mm aluminum plate

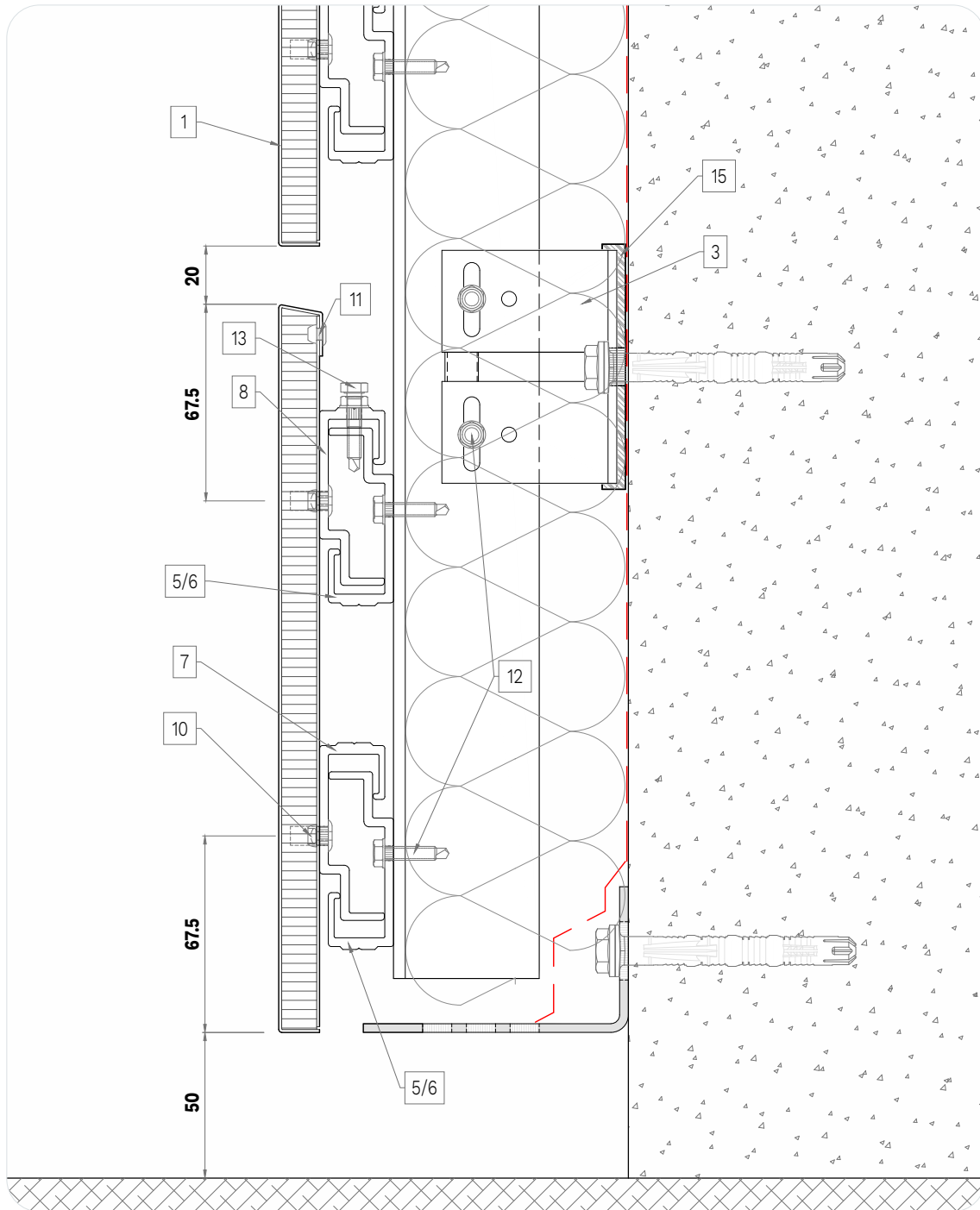

### 05. Façade starting

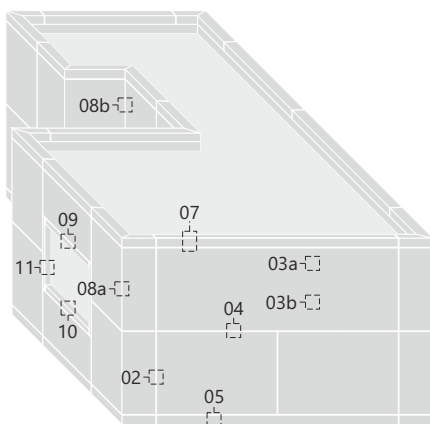

1. Iarcoring® A2 14 mm panel
2. LT-1A wind-weight bracket
3. LT-1B wind bracket
4. LT-2 vertical profile
5. PRO-5A long hanger
6. PRO-5B short hanger
7. PRO-6 standard clip
8. PRO-6R regulation clip
9. DOWSIL™ 7092 High adhesive and Sealant silicone
10. Hidefix 64090 rivet
11. NeoSpeed Ø4.8x5.8mm (ref. 57121-14805) rivet
12. DIN 7504-K Ø4.8x22mm A2/50 self-drilling screw
13. DIN 933 M5x12mm A2/50 hex head screw
14. SikaTack Panel 50 adhesive
15. LT-0A/B thermal break
16. 2-3mm aluminum plate

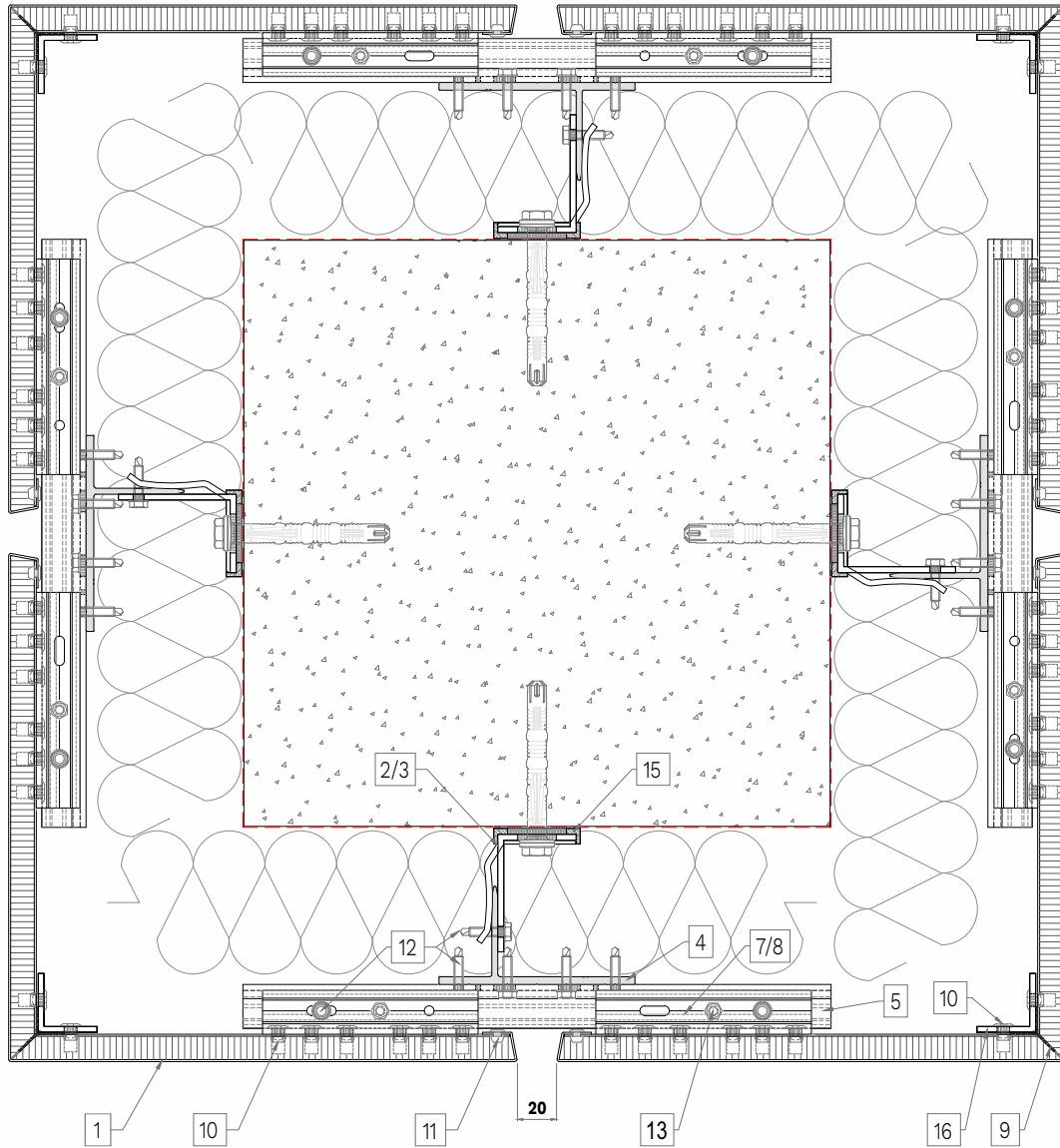

## 06. Columns

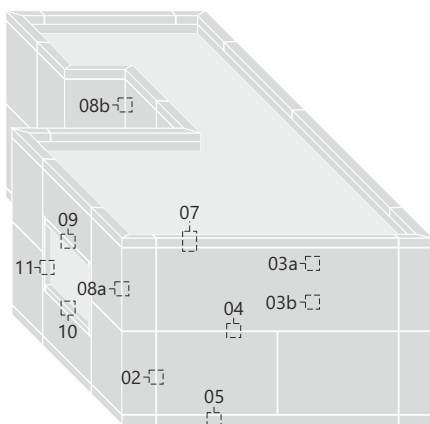

1. larcore® A2 14 mm panel
2. LT-1A wind-weight bracket
3. LT-1B wind bracket
4. LT-2 vertical profile
5. PRO-5A long hanger
6. PRO-5B short hanger
7. PRO-6 standard clip
8. PRO-6R regulation clip
9. DOWSIL™ 7092 High adhesive and Sealant silicone
10. Hidefix 64090 rivet
11. NeoSpeed Ø4.8x5.8mm (ref. 57121-14805) rivet
12. DIN 7504-K Ø4.8x22mm A2/50 self-drilling screw
13. DIN 933 M5x12mm A2/50 hex head screw
14. SikaTack Panel 50 adhesive
15. LT-0A/B thermal break
16. 2-3mm aluminum plate

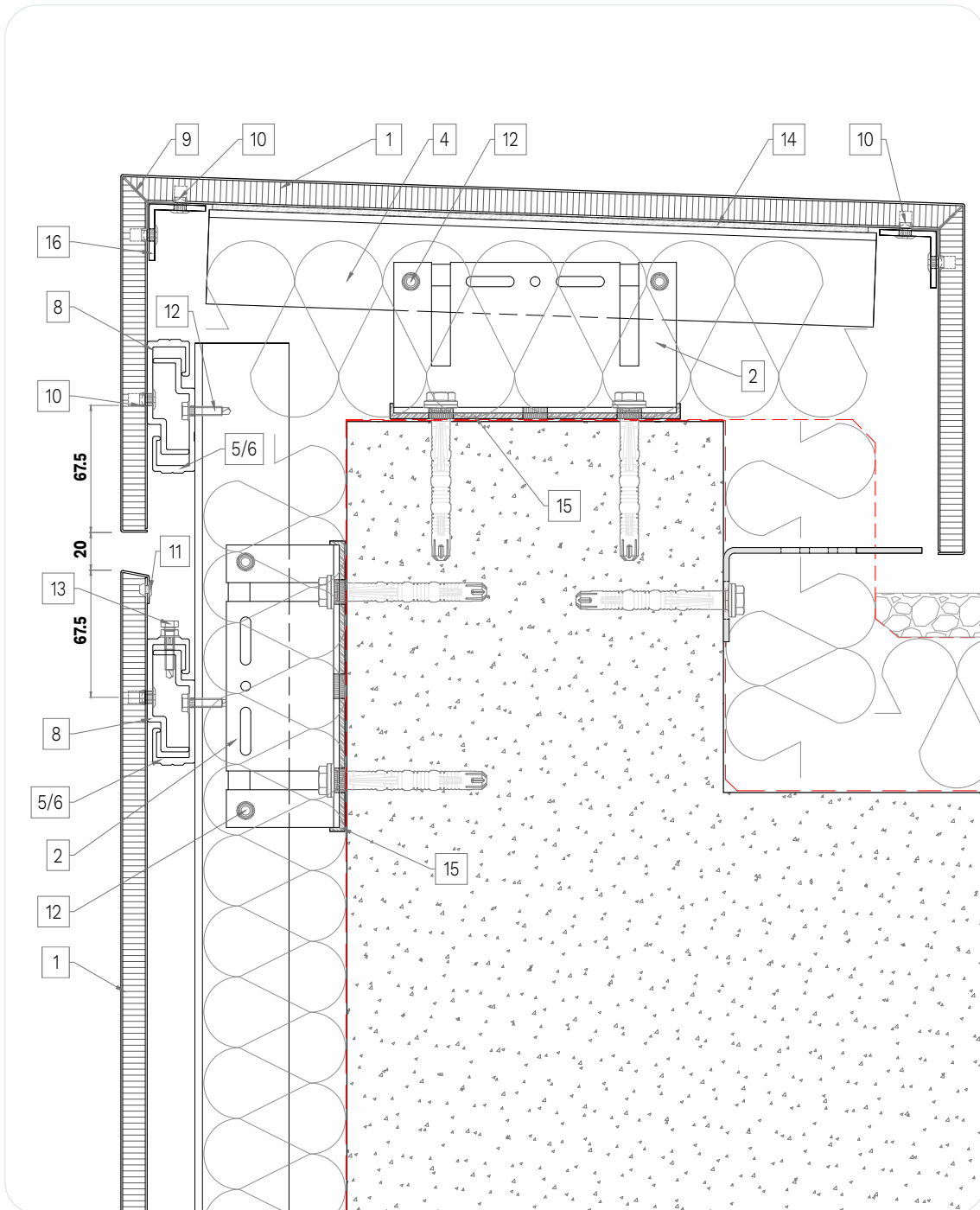

**07. Parapet detail**

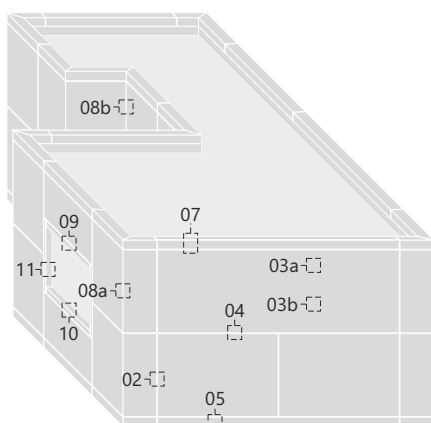

- 1. Iarc core® A2 14 mm panel**
- 2. LT-1A wind-weight bracket**
- 3. LT-1B wind bracket**
- 4. LT-2 vertical profile**
- 5. PRO-5A long hanger**
- 6. PRO-5B short hanger**
- 7. PRO-6 standard clip**
- 8. PRO-6R regulation clip**
- 9. DOWSIL™ 7092 High adhesive and Sealant silicone**
- 10. Hidefix 64090 rivet**
- 11. NeoSpeed Ø4.8x5.8mm (ref. 57121-14805) rivet**
- 12. DIN 7504-K Ø4.8x22mm A2/50 self-drilling screw**
- 13. DIN 933 M5x12mm A2/50 hex head screw**
- 14. SikaTack Panel 50 adhesive**
- 15. LT-0A/B thermal break**
- 16. 2-3mm aluminum plate**



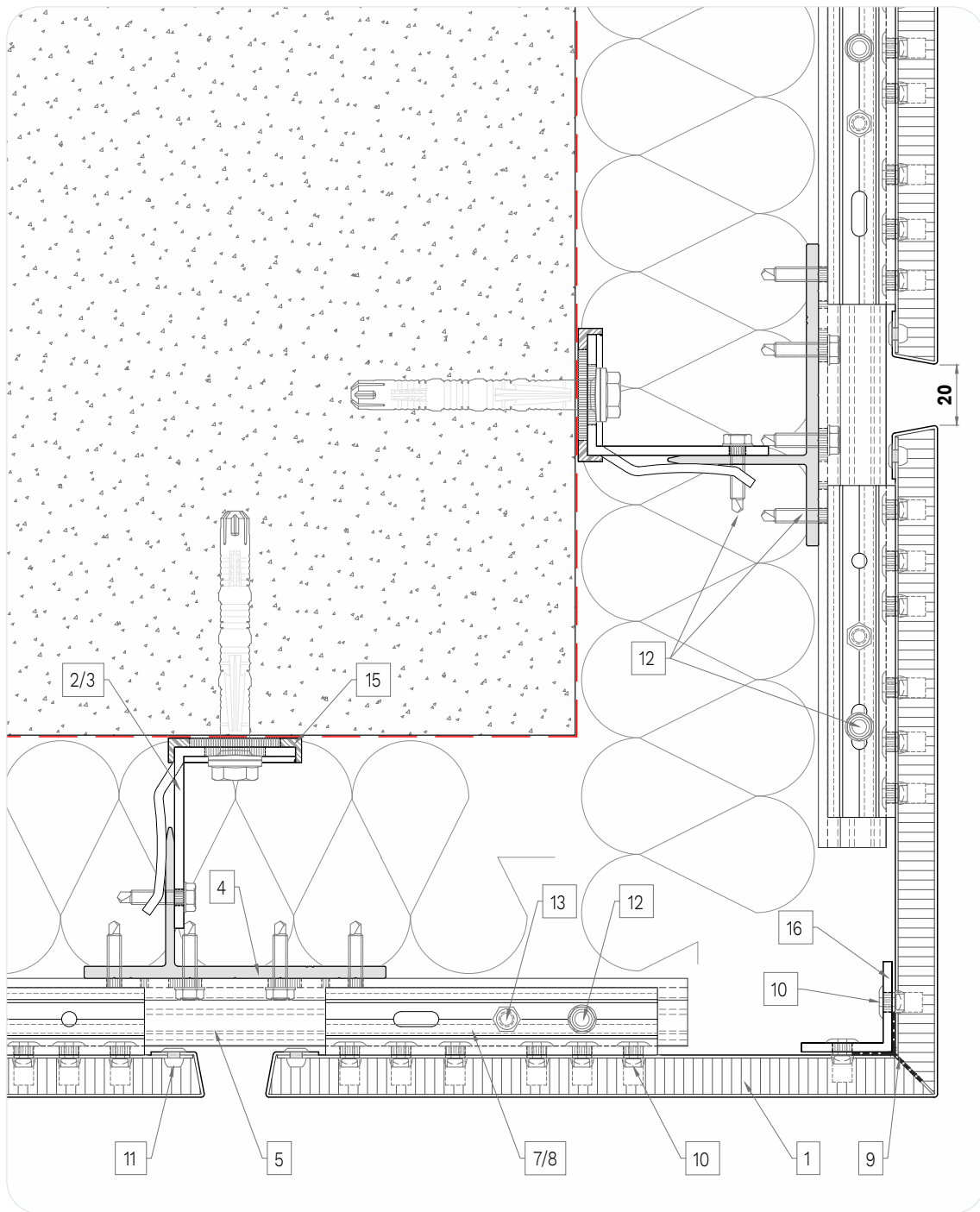

**08a. External corner**

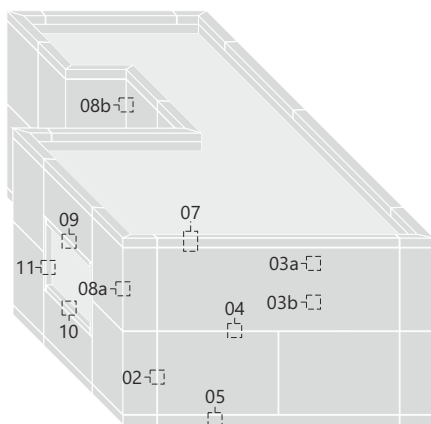

- 1.** larcore® A2 14 mm panel
- 2.** LT-1A wind-weight bracket
- 3.** LT-1B wind bracket
- 4.** LT-2 vertical profile
- 5.** PRO-5A long hanger
- 6.** PRO-5B short hanger
- 7.** PRO-6 standard clip
- 8.** PRO-6R regulation clip
- 9.** DOWSIL™ 7092 High adhesive and Sealant silicone
- 10.** Hidefix 64090 rivet
- 11.** NeoSpeed Ø4.8x5.8mm (ref. 57121-14805) rivet
- 12.** DIN 7504-K Ø4.8x22mm A2/50 self-drilling screw
- 13.** DIN 933 M5x12mm A2/50 hex head screw
- 14.** SikaTack Panel 50 adhesive
- 15.** LT-0A/B thermal break
- 16.** 2-3mm aluminum plate

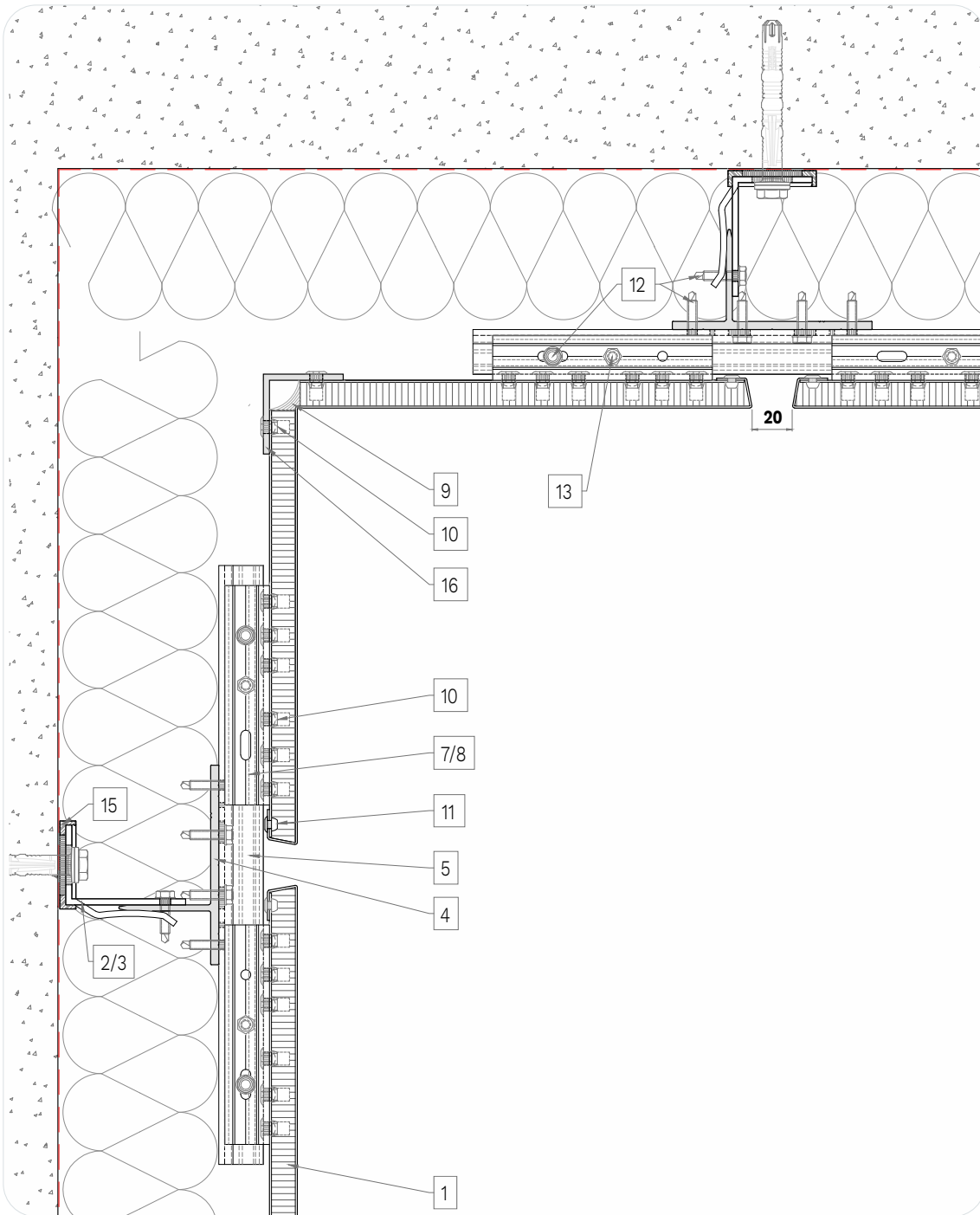

**08b. Internal corner**

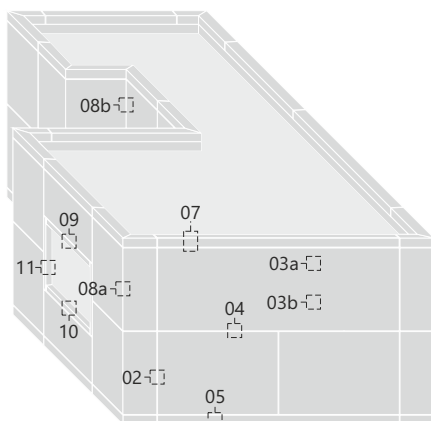

- 1. Iarc core® A2 14 mm panel**
- 2. LT-1A wind-weight bracket**
- 3. LT-1B wind bracket**
- 4. LT-2 vertical profile**
- 5. PRO-5A long hanger**
- 6. PRO-5B short hanger**
- 7. PRO-6 standard clip**
- 8. PRO-6R regulation clip**
- 9. DOWSIL™ 7092 High adhesive and Sealant silicone**
- 10. Hidefix 64090 rivet**
- 11. NeoSpeed Ø4.8x5.8mm (ref. 57121-14805) rivet**
- 12. DIN 7504-K Ø4.8x22mm A2/50 self-drilling screw**
- 13. DIN 933 M5x12mm A2/50 hex head screw**
- 14. SikaTack Panel 50 adhesive**
- 15. LT-0A/B thermal break**
- 16. 2-3mm aluminum plate**

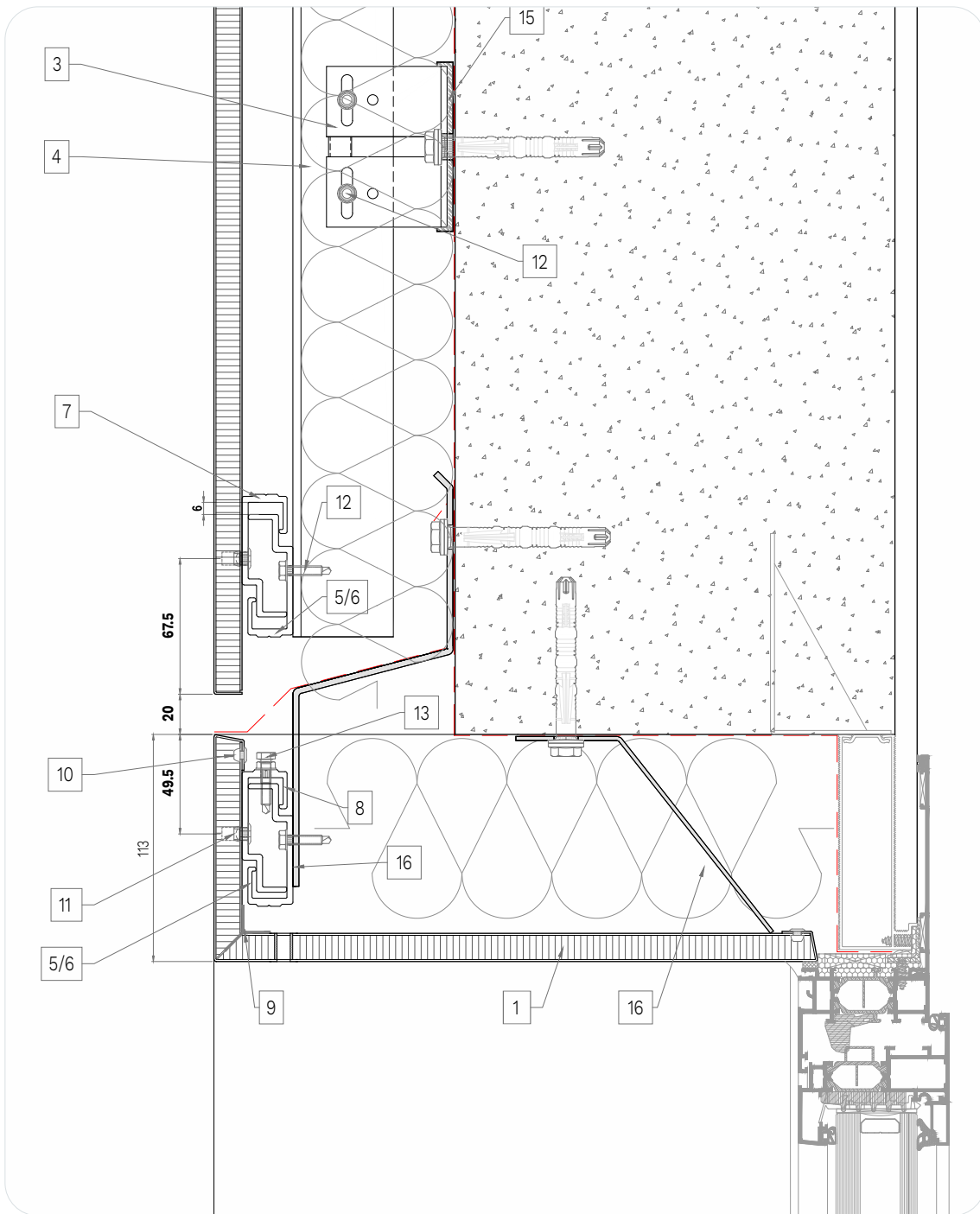

### 09. Window head detail

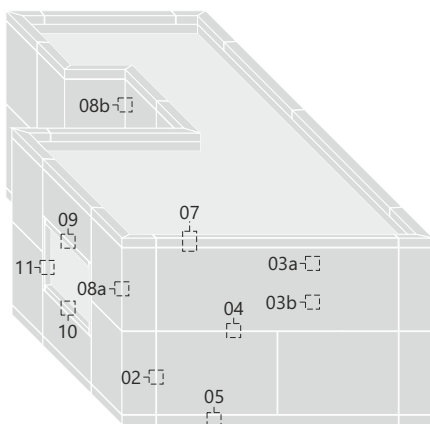

1. larcore® A2 14 mm panel
2. LT-1A wind-weight bracket
3. LT-1B wind bracket
4. LT-2 vertical profile
5. PRO-5A long hanger
6. PRO-5B short hanger
7. PRO-6 standard clip
8. PRO-6R regulation clip
9. DOWSIL™ 7092 High adhesive and Sealant silicone
10. Hidefix 64090 rivet
11. NeoSpeed Ø4.8x5.8mm (ref. 57121-14805) rivet
12. DIN 7504-K Ø4.8x22mm A2/50 self-drilling screw
13. DIN 933 M5x12mm A2/50 hex head screw
14. SikaTack Panel 50 adhesive
15. LT-0A/B thermal break
16. 2-3mm aluminum plate

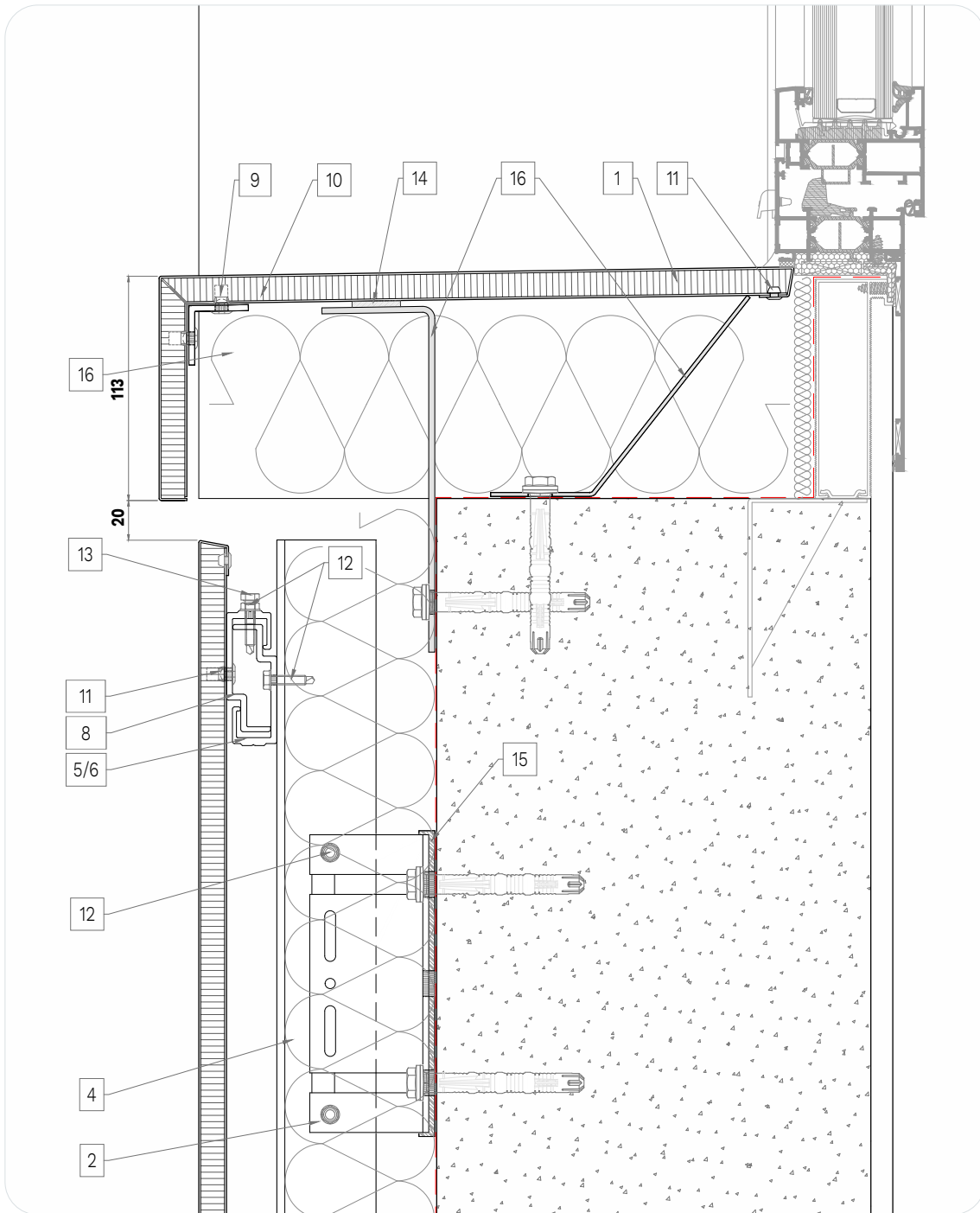

**10. Window sill detail**

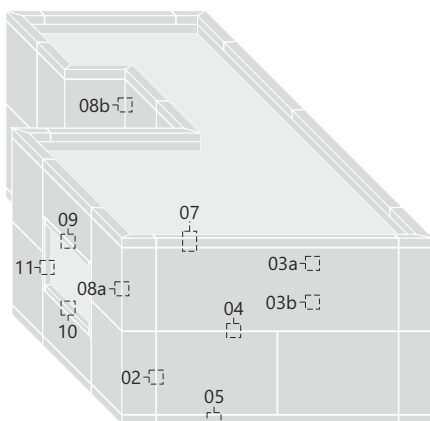

- 1. Iarc core® A2 14 mm panel**
- 2. LT-1A wind-weight bracket**
- 3. LT-1B wind bracket**
- 4. LT-2 vertical profile**
- 5. PRO-5A long hanger**
- 6. PRO-5B short hanger**
- 7. PRO-6 standard clip**
- 8. PRO-6R regulation clip**
- 9. DOWSIL™ 7092 High adhesive and Sealant silicone**
- 10. Hidefix 64090 rivet**
- 11. NeoSpeed Ø4.8x5.8mm (ref. 57121-14805) rivet**
- 12. DIN 7504-K Ø4.8x22mm A2/50 self-drilling screw**
- 13. DIN 933 M5x12mm A2/50 hex head screw**
- 14. SikaTack Panel 50 adhesive**
- 15. LT-0A/B thermal break**
- 16. 2-3mm aluminum plate**

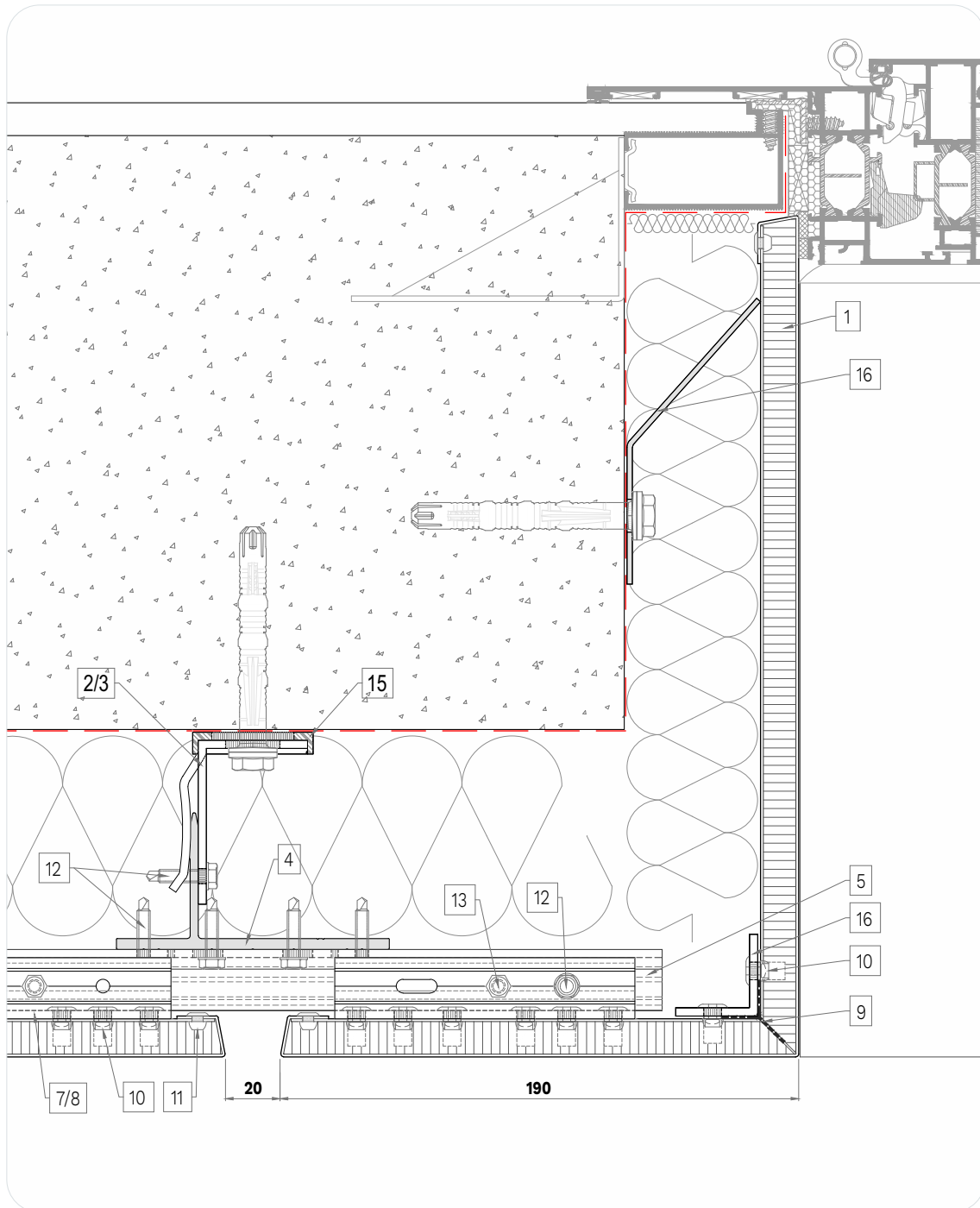

### 11. Window jamb detail

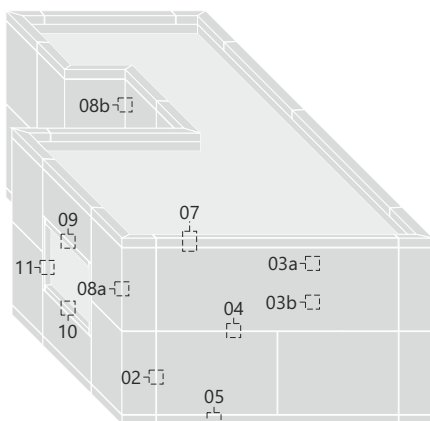

- 1. larcore® A2 14 mm panel
- 2. LT-1A wind-weight bracket
- 3. LT-1B wind bracket
- 4. LT-2 vertical profile
- 5. PRO-5A long hanger
- 6. PRO-5B short hanger
- 7. PRO-6 standard clip
- 8. PRO-6R regulation clip
- 9. DOWSIL™ 7092 High dhesive and Sealant silicone
- 10. Hidefix 64090 rivet
- 11. NeoSpeed Ø4.8x5.8mm (ref. 57121-14805) rivet
- 12. DIN 7504-K Ø4.8x22mm A2/50 self-drilling screw
- 13. DIN 933 M5x12mm A2/50 hex head screw
- 14. SikaTack Panel 50 adhesive
- 15. LT-0A/B thermal break
- 16. 2-3mm aluminum plate



## Iarcoring® A2



Housing building, 90 King Street Flinders,  
VIC, Australia.  
**Iarcoring® A2** Anodized Dark Grey  
Architect: Bruce Henderson & Mim Design  
Photographer: Xhejs Koci



# Specialists in the Manufacture of **Metal** and **Honeycomb Panels** for **Architectural Envelopes**

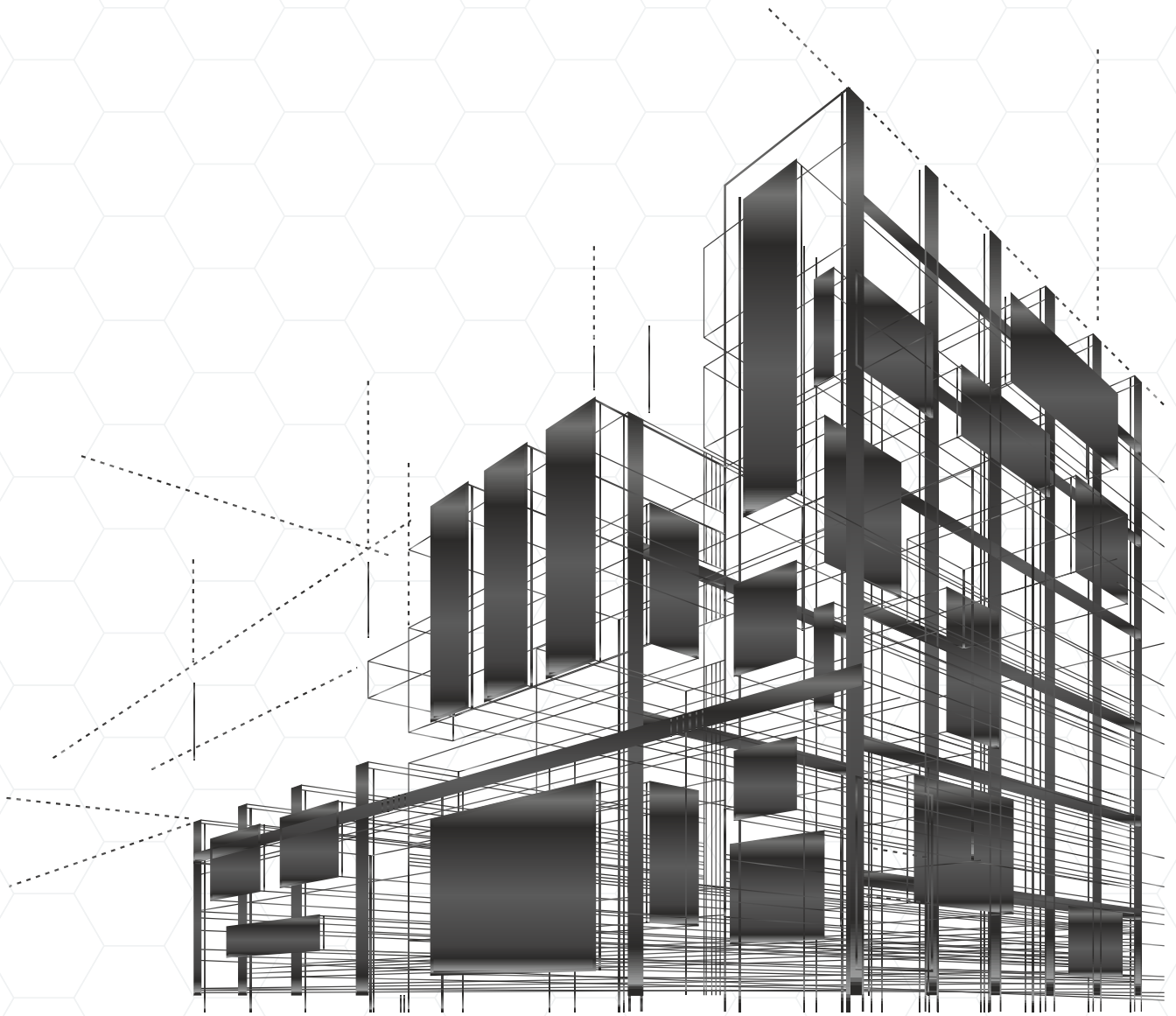

## **Alucoil**<sup>®</sup>

Grupo Alibérico

Polígono Industrial de Bayas. C/Ircio. Parcelas R72-77

09200 Miranda de Ebro, Burgos. SPAIN

Tlf: +34 947 333 320

info@alucoil.com

### **www.alucoil.com**

**Alucoil**<sup>®</sup> S.A.U. reserves the right to change or remove information contained in this brochure without prior notice.  
Please visit us at **www.alucoil.com** to check the latest version.